

SONY®

Cyber-shot

Digital Still Camera

Cyber-shot Handbook

DSC-S730

Before operating the unit, please read this Handbook thoroughly together with the “*Instruction Manual*” and the “*Cyber-shot Step-up Guide*”, and retain them for future reference.

▼CLICK!



Table of contents



Basic Operations



Using the menu



Using the Setup screen



Viewing images on a TV



Using your computer



Printing still images



Troubleshooting



Others



Index

Notes on using your camera

Notes on the types of “Memory Stick” that you can use (not supplied)

“Memory Stick Duo”

You can use a “Memory Stick Duo” with the camera.



“Memory Stick”

You cannot use a “Memory Stick” with the camera.



Other memory cards cannot be used.

- For details on “Memory Stick Duo”, see page 95.

When using a “Memory Stick Duo” with “Memory Stick” compatible equipment

You can use the “Memory Stick Duo” by inserting it into the Memory Stick Duo Adaptor (not supplied).



Memory Stick Duo Adaptor

Notes on the LCD screen and lens

- The LCD screen is manufactured using extremely high-precision technology, so over 99.99% of the pixels are operational for effective use. However, some tiny black and/or bright dots (white, red, blue or green) may appear on the LCD screen. These dots are a normal result of the manufacturing process, and do not affect the recording.

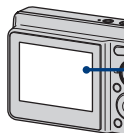

Black, white, red, blue or green points

- Exposing the LCD screen or the lens to direct sunlight for long periods may cause malfunctions. Be careful when placing the camera near a window or outdoors.
- Do not press against the LCD screen. The screen may be discolored and that may cause a malfunction.
- Images may trail across on the LCD screen in a cold location. This is not a malfunction.
- This camera is equipped with a power zoom lens. Be careful not to bump the lens, and be careful not to apply force to it.

The images used in this Handbook

The images used as examples in this Handbook are reproduced images, and are not actual images shot using the camera.







Table of contents







Notes on using your camera	2
Basic techniques for better images	6
Focus – Focusing on a subject successfully	6
Exposure – Adjusting the light intensity	8
Color – On the effects of lighting	9
Quality – On “image quality” and “image size”	10
Flash – On using the flash	11
Identifying parts	12
Indicators on the screen	14
Changing the screen display	18
Using the internal memory	19

Basic Operations





Using the mode dial.....	20
Shooting images easily (Auto adjustment mode)	21
Shooting still images (Scene selection).....	25
Viewing/deleting images.....	28

Using the menu

<i>Using menu items</i>	30
<i>Menu items</i>	31
Shooting menu	32
COLOR (Color Mode): Changing the vividness of the image or adding special effects	
 (EV): Adjusting the light intensity	
 (Focus): Changing the focus method	
 (Metering Mode): Selecting the metering mode	
WB (White Bal): Adjusting the color tones	
ISO: Selecting a luminous sensitivity	
Mode (REC Mode): Selecting the continuous shooting method	
 (Flash Level): Adjusting the amount of flash light	
 (Sharpness): Adjusting the sharpness of the image	
 (Setup): Changing Setup items	

Viewing menu	41
<ul style="list-style-type: none">  (Folder): Selecting the folder for viewing images  (Protect): Preventing accidental erasure DPOF: Adding a Print order mark  (Print): Printing images using a printer  (Slide): Playing back a series of images  (Resize): Changing the image size of a recorded image  (Rotate): Rotating a still image  (Setup): Changing Setup items Trimming: Recording an enlarged image 	

Using the Setup screen

<i>Using Setup items</i>	48
 Camera	49
<ul style="list-style-type: none"> Digital Zoom Function Guide Red Eye Reduction Auto Review 	
 Internal Memory Tool.....	51
Format	
 Memory Stick Tool.....	52
<ul style="list-style-type: none"> Format Create REC. Folder Change REC. Folder Copy 	
 Setup1.....	55
<ul style="list-style-type: none"> Beep Language Initialize 	
 Setup2.....	56
<ul style="list-style-type: none"> USB Connect Video Out Clock Set 	

Viewing images on a TV

Viewing images on a TV	58
------------------------------	----

Using your computer

Enjoying your Windows computer	60
Installing the software (supplied)	62
On the “Picture Motion Browser” (supplied)	64
Copying images to your computer using the “Picture Motion Browser”	65
Copying images to a computer without “Picture Motion Browser”	69
Viewing image files stored on a computer with the camera copying to the “Memory Stick Duo”	71
Using your Macintosh computer	72
Viewing “Cyber-shot Step-up Guide”	74

Printing still images

How to print still images	75
Printing images directly using a PictBridge compliant printer	76
Printing at a shop	80

Troubleshooting

Troubleshooting	82
Warning messages	92

Others

Using the camera abroad — Power sources	94
On the “Memory Stick Duo”	95
On the batteries	97

Index

Index	98
-------------	----

Basic techniques for better images

Focus

Exposure

Color

Quality

Flash



This section describes the basics so you can enjoy your camera. It tells you how to use various camera functions such as the mode dial (page 20), and the menus (page 30).

Focus *Focusing on a subject successfully*

When you press the shutter button halfway down, the camera adjusts the focus automatically (Auto Focus). Remember to press the shutter button only halfway down.

Do not fully press the shutter button straight away.



Press the shutter button halfway down.

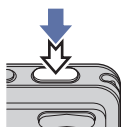

AE/AF lock indicator flashing → lit/beeps



Then press the shutter button fully down.

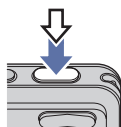

When focusing is difficult → [Focus] (page 34)

If the image looks blurred even after focusing, it may be because of camera shake. → See “Hints for preventing blur” as follows.

Hints for preventing blur

The camera moved accidentally when you took the image. This is called “Camera shake.” On the other hand, if the subject moved when you took the image, it is called “subject blur.”

Camera shake



Cause

Your hands or body shake while you hold the camera and press the shutter button, and the entire screen is blurred.

What you can do to reduce the blurring

- Use a tripod or place the camera on a flat surface to hold the camera steady.
- Shoot with a 2-second delay self-timer and stabilize the camera by holding your arms firmly at your side after pressing the shutter button.

Subject blur





Cause

Even though the camera is steady, the subject moves during the exposure so the subject looks blurred when the shutter button is pressed.

What you can do to reduce the blurring

- Select  (High Sensitivity mode) in Scene Selection.
- Select a higher ISO sensitivity to make the shutter speed faster, and press the shutter button before the subject moves.

Notes

Besides, camera shake and subject blur occur frequently under low-light or slow shutter speed conditions, such as those encountered in  (Twilight mode) or  (Twilight Portrait mode). In that case, shoot with the above tips in mind.

Exposure *Adjusting the light intensity*

You can create various images by adjusting the exposure and the ISO sensitivity. Exposure is the amount of light that the camera will receive when you release the shutter.

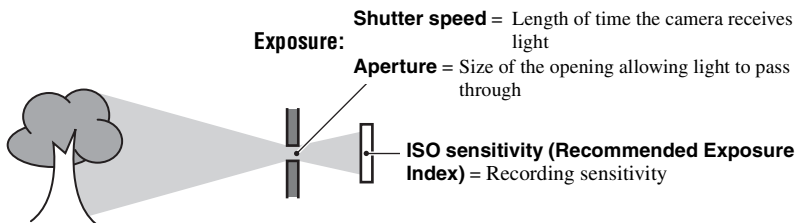

Overexposure
= too much light
Whitish image

The exposure is automatically set to the proper value in the auto adjustment mode. However, you can adjust it manually using the functions below.



Correct exposure

Adjusting EV:

Allows you to adjust the exposure determined by the camera (page 33).



Underexposure
= too little light
Darker image

Metering Mode:

Allows you to change the part of the subject to be measured to determine the exposure (page 36).

Adjusting the ISO sensitivity (Recommended Exposure Index)

ISO sensitivity is a speed rating for recording media that incorporates an image sensor that receives light. Even when the exposure is the same, images differ depending on the ISO sensitivity.

To adjust the ISO sensitivity, see page 38.



High ISO sensitivity

Records a bright image even in dark locations while increasing shutter speed to reduce blur. However, the image tends to become noisy.



Low ISO sensitivity





Records a smoother image. However, when the exposure is insufficient, the image may become darker.

Color

On the effects of lighting

The apparent color of the subject is affected by the lighting conditions.

Example: The color of an image affected by light sources

Weather/lighting	Daylight	Cloudy	Fluorescent	Incandescent
Characteristics of light	White (standard) 	Bluish 	Green-tinged 	Reddish 

The color tones are adjusted automatically in the auto adjustment mode. However, you can adjust color tones manually with [White Bal] (page 37).

Quality On “image quality” and “image size”

A digital image is made up of a collection of small dots called pixels.

If it contains a large number of pixels, the picture becomes large, it takes up more memory, and the image is displayed in fine detail. “Image size” is shown by the number of pixels.

Although you cannot see the differences on the screen of the camera, the fine detail and data processing time differ when the image is printed or displayed on a computer screen.

Description of the pixels and the image size

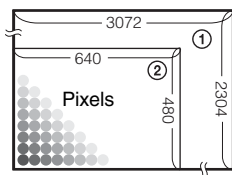

- ① Image size: 7M
 $3072 \text{ pixels} \times 2304 \text{ pixels} = 7,077,888 \text{ pixels}$
- ② Image size: VGA(E-Mail)
 $640 \text{ pixels} \times 480 \text{ pixels} = 307,200 \text{ pixels}$

Selecting the image size for use (page 24)

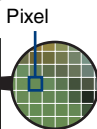
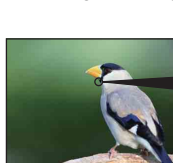

Many pixels (Fine image quality and large file size)



Example: Printing in up to A3 size



Few pixels (Rough image quality but small file size)



Example: An attached image to be sent by e-mail

Flash On using the flash

The eyes of the subject may come out red, or fuzzy white circular spots may appear when using the flash. These phenomena can be reduced by taking the following steps.

The “Red-eye phenomenon”

Pupils become dilated in dark environments. Flash light is reflected off the blood vessels at the back of the eye (retina), causing the “red-eye” phenomenon.



How can the “Red-eye phenomenon” be reduced?

- Set [Red Eye Reduction] to [On] (page 50).
- Select iso (High Sensitivity mode)* in Scene Selection (page 26). (The flash is turned off automatically.)
- When the eyes of the subject turn out red, correct the image with the supplied software “Picture Motion Browser”.

“White circular spots”

This is caused by particles (dust, pollen, etc.) floating close to the lens. When they are accentuated by the camera’s flash, they appear as white circular spots.

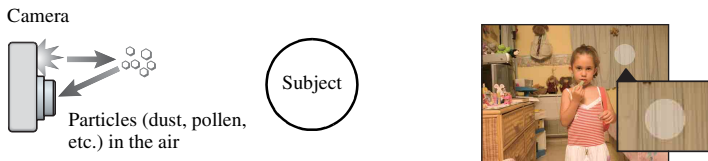

How can the “White circular spots” be reduced?

- Light the room and shoot the subject without a flash.
- Select iso (High Sensitivity mode)* in Scene Selection. (The flash is turned off automatically.)

*Even though you selected iso (High Sensitivity mode) in Scene Selection, the shutter speed might be slower under low-light conditions, or in a dark place. In that case, use a tripod or hold your arms firmly at your side after pressing the shutter button.

Identifying parts

See the pages in parentheses for details of operation.

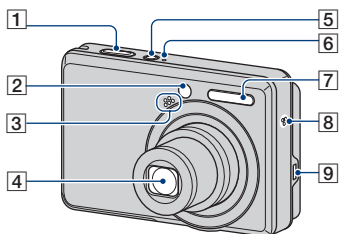

- 1** Shutter button (21)
- 2** Self-timer lamp (23)
- 3** Microphone
- 4** Lens
- 5** POWER button
- 6** POWER lamp
- 7** Flash (22)
- 8** Buzzer
- 9** (USB) · A/V OUT terminal (side)

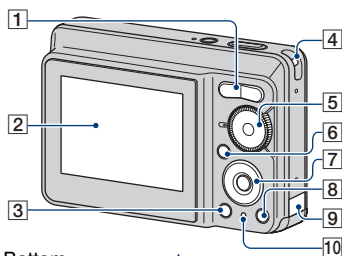

Bottom

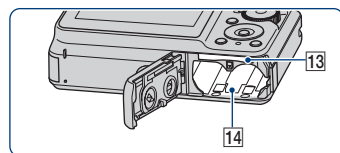
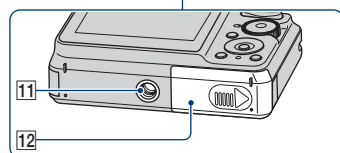

- 1** For shooting: Zoom (W/T) button (22)
For viewing: (Playback zoom) button/ (Index) button (28, 29)
- 2** LCD screen (18)
- 3** (Playback) button (28)
- 4** Hook for strap
- 5** Mode dial (20)
- 6** MENU button (30)
 - Press MENU longer to display the (Setup) screen.
- 7** Control button
 - Menu on: (30)
 - Menu off: DISP/ (18, 22-23)
- 8** For shooting: (Image Size) button (24)
For viewing: (Delete) button (28)

Identifying parts

- 9** AC adaptor cord cover
When using an AC-LS5K AC Adaptor
(not supplied)

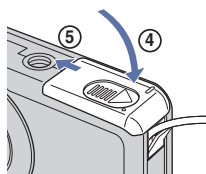
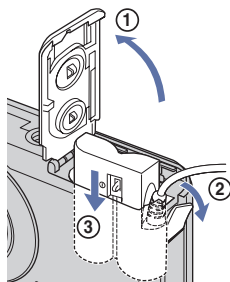

- Do not pinch the cord when you close the cover.
- You cannot charge the Nickel-Metal Hydride batteries by the AC-LS5K AC Adaptor. Use the battery charger to charge the Nickel-Metal Hydride batteries.

- 10** Access lamp

- 11** Tripod receptacle

- Use a tripod with a screw less than 5.5 mm (7/32 inch) long. Otherwise, you cannot firmly secure the camera, and damage to the camera may occur.

- 12** Battery/“Memory Stick Duo” cover

- 13** “Memory Stick Duo” slot

- 14** Batteries insertion slot

Indicators on the screen

Each time you press ▲ (DISP) on the control button, the display changes (page 18).

See the pages in parentheses for details of operation.

When shooting still images

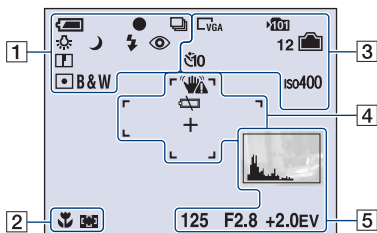

When shooting movies

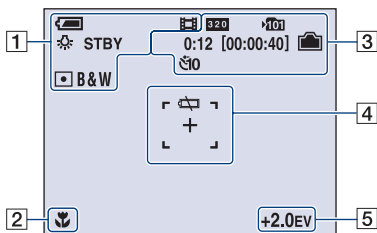

1

Display	Indication
	Battery remaining
	AE/AF lock (21)
	Recording mode (21, 39)
	White balance (37)
STBY REC	Standby/Recording a movie
	Mode dial (Scene Selection) (25)
P	Mode dial (Program Auto) (20)
	Camera mode
	Flash mode (22)
	Flash charging
	Zoom scaling (22, 49)
	Red-eye reduction (50)
	Sharpness (40)
	Metering mode (36)
RICH NATURAL SEPIA B&W	Color mode (32)

2

Display	Indication
	Macro (23)
	AF range finder frame indicator (34)
1.0 m	Focus preset distance (34)

3

Display	Indication
	Image size (24)
	Recording folder (52) <ul style="list-style-type: none"> This does not appear when using internal memory.
	Remaining internal memory capacity
	Remaining "Memory Stick" capacity
0:12 [00:00:40]	Recording time [maximum recordable time]
12	Remaining number of recordable images
	Self-timer (23)
iso400	ISO number (38)

4

Display	Indication
	Vibration warning <ul style="list-style-type: none"> Indicates vibration may prevent you from shooting clear images due to insufficient lighting. Even if the vibration warning appears, you can still shoot images. However, we recommend that you use the flash for better lighting or using a tripod or other means to stabilize the camera (page 7).
	Low battery warning (92)
+	Spot metering cross hairs (36)
	AF range finder frame (34)

5

Display	Indication
	Histogram (18)
125	Shutter speed
F2.8	Aperture value
+2.0EV	Exposure Value (33)
	Menu (30) (not displayed on the screen on the previous page)

When playing back still images

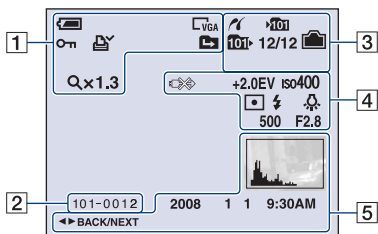

When playing back movies

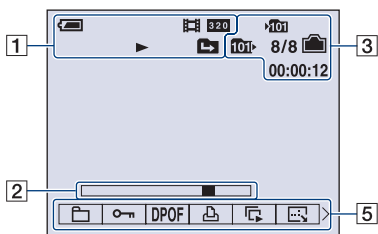





1

Display	Indication
	Battery remaining
	Recording mode (21)
	Image size (24)
	Playback mode
	Protect (42)
	Print order (DPOF) mark (80)
	Changing folder (41) • This does not appear when using internal memory.
	Zoom scaling (28)
	Playback (28)





2

Display	Indication
101-0012	Folder-file number (41)
	Playback bar



3

Display	Indication
	PictBridge connecting (77)
	Recording folder (52) <ul style="list-style-type: none"> This does not appear when using internal memory.
	Playback folder (41) <ul style="list-style-type: none"> This does not appear when using internal memory.
	Remaining internal memory capacity
	Remaining "Memory Stick" capacity
8/8 12/12	Image number/Number of images recorded in selected folder
00:00:12	Counter

4

Display	Indication
	PictBridge connecting (78) <ul style="list-style-type: none"> Do not disconnect the dedicated USB cable while the icon is displayed.
+2.0EV	Exposure Value (33)
ISO400	ISO number (38)
	Metering mode (36)
	Flash
	White balance (37)
500	Shutter speed
F2.8	Aperture value

5

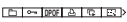
Display	Indication
	Histogram (18) <ul style="list-style-type: none">  appears when histogram display is disabled.
2008 1 1 9:30 AM	Recorded date/time of the playback image
	Menu (30)
◀▶ BACK/ NEXT	Selecting images

Changing the screen display

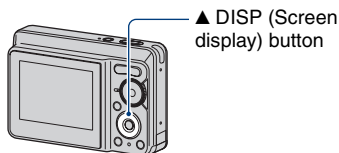

▲ DISP (Screen display) button

Each time you press ▲ (DISP) on the control button, the display changes as follows:

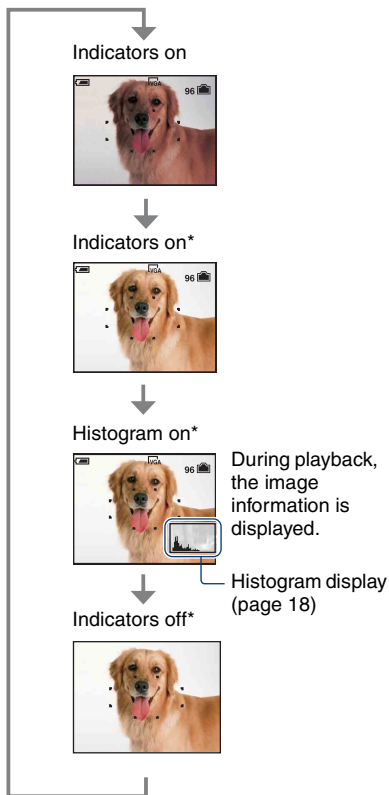

*The brightness of the LCD Backlight up

- If you view images in bright outside light, adjust the brightness of the LCD backlight up. However, the battery power may decrease faster under such condition.
- The histogram does not appear in the following situations:
 - While shooting
 - When the menu is displayed.
 - When recording movies.
 - During playback
 - When the menu is displayed.
 - In index mode.
 - When you are using playback zoom.
 - When you are rotating still images.
 - During playback of movies.
- A large difference in the histogram displayed during shooting and playback may occur when:
 - The flash strobes.
 - The shutter speed is slow or fast.
- The histogram may not appear for images recorded using other cameras.

Adjusting EV (Exposure Value) by displaying a histogram

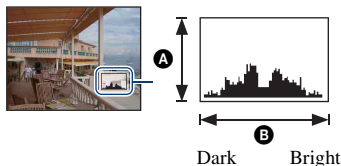

A histogram is a graph showing the brightness of an image. Press ▲ (DISP) on the control button repeatedly to display the histogram on the screen. The graph display indicates a bright image when skewed to the right side, and a dark image when skewed to the left side.

- ▲ Number of pixels
- Brightness

- The histogram also appears when playing back a single image, but you cannot adjust the exposure.

Using the internal memory

The camera has approximately 22 MB of internal memory. This memory is not removable. Even when there is no “Memory Stick Duo” inserted in the camera, you can record images using this internal memory.

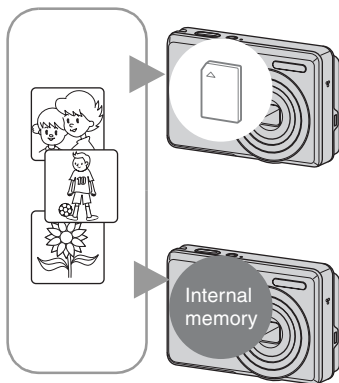

When a “Memory Stick Duo” is inserted

[Recording]: Images are recorded on the “Memory Stick Duo”.

[Playback]: Images on the “Memory Stick Duo” are played back.

[Menu, Setup, etc.]: Various functions can be performed on images on the “Memory Stick Duo”.

When there is no “Memory Stick Duo” inserted

[Recording]: Images are recorded using the internal memory.

[Playback]: Images stored in the internal memory are played back.

[Menu, Setup, etc.]: Various functions can be performed on images in the internal memory.

On image data stored in the internal memory

We recommend that you copy (back up) data without error using one of the following methods.

To copy (back up) data on a “Memory Stick Duo”

Prepare a “Memory Stick Duo” with sufficient free capacity, then perform the procedure explained in [Copy] (page 54).

To copy (back up) data on a hard disk of your computer

Perform the procedure on pages 65, 66 or 69, 70 without a “Memory Stick Duo” inserted in the camera.

- You cannot copy image data on a “Memory Stick Duo” to the internal memory.
- By connecting the camera and a computer with a dedicated USB cable, you can copy data stored in the internal memory to a computer. However you cannot copy data on a computer to the internal memory.

Using the mode dial

Set the mode dial to the desired function.

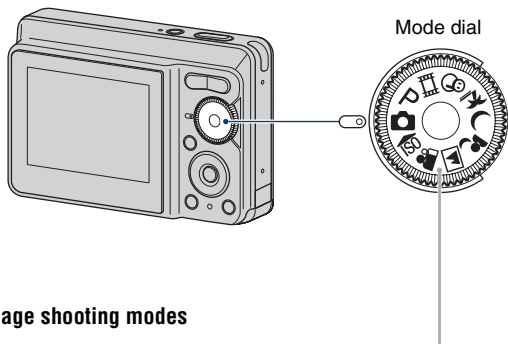

Still image shooting modes

 **Auto Adjustment mode**

Allows easy shooting with the settings adjusted automatically. → page 21

P : **Program Auto mode**

Allows you to shoot with the exposure adjusted automatically (both the shutter speed and the aperture value). Also you can select various settings using the menu.

(For details on the functions available → page 31)

 **Movie recording mode**

Allows you to record movies. → page 21

       : **Scene Selection mode**

Allows you to shoot with preset settings according to the scene. → page 25

On Function Guide

When [Function Guide] is set to [On], the descriptions of functions are displayed as you operate the camera.

The default setting is [On]. Select [Off] if you do not want the function guide to appear (page 50).

Shooting images easily (Auto adjustment mode)

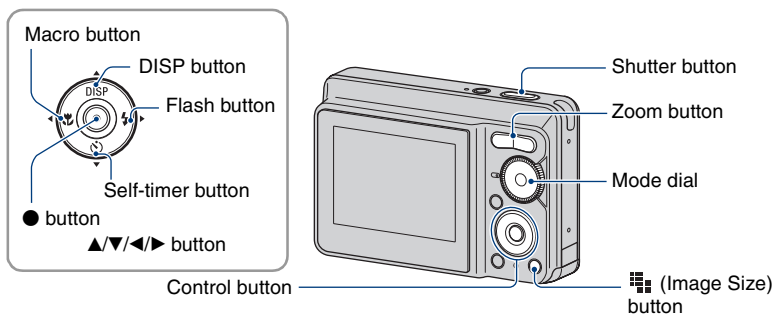

1 Select a mode with the mode dial.

Still image (auto adjustment mode): Select .

Movie: Select .

2 Hold the camera steady, keeping your arms at your side.



Position the subject in the center of the focus frame.

3 Shoot with the shutter button.

Still image:

① Press and hold the shutter button halfway down to focus.

The ● (AE/AF lock) indicator (green) flashes, a beep sounds, the indicator stops flashing and remains lit.

AE/AF lock indicator

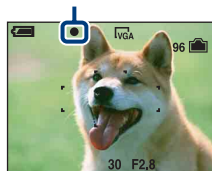

② Press the shutter button fully down.

The shutter sounds.

Movie:

Press the shutter button fully down.

To stop recording, press the shutter button fully down again.

If you shoot a still image of a subject that is difficult to focus on

- The shortest shooting distance is approx. 50 cm (1 feet 7 3/4 inches) (From the front of the lens). Shoot in the close-up (Macro) mode (page 23) when you shoot a subject closer than the shooting distance.
- When the camera cannot focus on the subject automatically, the AE/AF lock indicator changes to flash slowly and the beep does not sound. In addition, the AF range finder frame disappears. Recompose the shot and focus again.

Focusing may be difficult in the following situations:

- It is dark and the subject is distant.
- The contrast between the subject and the background is poor.
- The subject is seen through glass.
- The subject is moving quickly.
- There is reflective light or shiny surfaces.
- The subject is backlit or there is a flashing light.

W/T Using the zoom

Press T to zoom, press W to undo the zoom.

- When the zoom scale exceeds 3x, the camera uses the Digital Zoom function.
For details on the [Digital Zoom] settings and the image quality, see page 49.
- You cannot change the zoom scale while shooting a movie.

⚡ Flash (Selecting a flash mode for still images)

Press **▶ (⚡)** on the control button repeatedly until the desired mode is selected.



(No indicator): Flash Auto

Strobes when there is insufficient light (default setting)

⚡: Flash forced on

⚡SL: Slow synchro (Flash forced on)

The shutter speed is slow in a dark place to clearly shoot the background that is out of flash light.

⊙: Flash forced off

- The flash strobes twice. The first flash adjusts the light quantity.
- While charging the flash, **⚡•** is displayed.

Macro (Shooting close-up)

Press ◀ () on the control button repeatedly until the desired mode is selected.

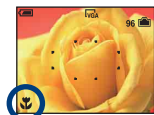

(No indicator): Macro Off

: Macro On (W side: Approx. 5 cm or farther (2 inches or farther), T side: Approx. 35 cm or farther (13 7/8 inches or farther) from the front of the lens)

- Setting the zoom all the way to the W side is recommended.
- The in-focus range becomes narrow, and the subject may not be entirely in focus.
- The Auto Focus speed drops when you shoot images in the Macro.

Using the self-timer

Press ▼ () on the control button repeatedly until the desired mode is selected.



(No indicator): Not using the self-timer

: Setting the 10-second delay self-timer

: Setting the 2-second delay self-timer



When you press the shutter button, the self-timer lamp flashes and a beep sounds until the shutter operates.



To cancel, press ▼ () again.

- Use the 2-second delay self-timer to prevent blur of an image. The shutter is released 2 seconds after you press the shutter button, which reduces camera shake when the shutter button is pressed.

To change the still image size

Press  (Image Size), and then press / to select the size.

For details on the image size, see page 10.









The default setting is marked with .

	Image size	Guidelines	No. of images	Printing
	7M (3072×2304)	Up to A3/11×17" print	Less    More	Fine    Rough
	3:2* ¹ (3072×2048)	Match 3:2 Aspect Ratio		
	5M (2592×1944)	Up to A4/8×10" print		
	3M (2048×1536)	Up to 13×18cm /5×7" print		
	VGA (640×480)	For E-mail		
	16:9* ² (1920×1080)	Display On 16:9 HDTV		

*¹) Images are recorded in 3:2 aspect ratio, same as photograph printing paper or postcards, etc.

*²) Both edges of the image may be cut off when printing (page 89).

Shooting still images (Scene selection)

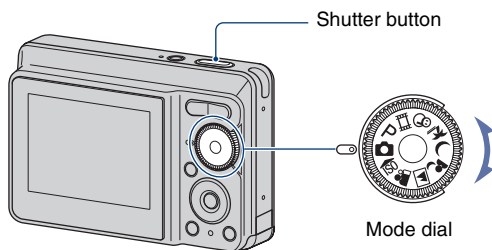

1 Select the desired mode of Scene Selection (ISO, , , , , , , ).

- For details on modes, see the next page.

2 Shoot with the shutter button.

To cancel the Scene Selection

Set the mode dial to other than the mode of Scene Selection (page 20).

Scene Selection modes

The following modes are preset to match the scene conditions.



 **High Sensitivity**
Allows you to shoot images without a flash under low light conditions, reducing blur.



 **Soft Snap**
Allows you to shoot skin colors in brighter and warmer tones for more beautiful pictures. In addition, the soft focus effect creates a gentle atmosphere for portraits of people, flowers, etc.



 **Landscape**
Focuses only on a distant subject to shoot landscapes, etc.



 **Twilight Portrait***
Allows you to shoot sharp images of people with the night view in the background without compromising the atmosphere.





 **Twilight***
Allows you to shoot night scenes at far distance without losing the dark atmosphere of the surroundings.



 **Beach**
When shooting seaside or lakeside scenes, the blue of the water is clearly recorded.















 **Snow**
When shooting snowy scenes or other places where the whole screen appears white, use this mode to prevent sunken colors and record clear images.

*When you shoot images using  (Twilight Portrait) or  (Twilight) mode, the shutter speed becomes slower, and blurring is occur frequently, so use of a tripod is recommended.

Functions you can use in Scene Selection

For shooting an image appropriately according to the scene condition, a combination of functions is determined by the camera. Some functions are not available, depending on the Scene Selection mode. When you press the button to select functions that cannot be combined with Scene Selection, a beep sounds.

(✓: you can select the desired setting)

	Macro	Flash	White Balance	Burst
	✓		✓*	✓
	✓	✓	—	✓
	—		—	✓
	✓		—	—
	—		—	—
	✓		—	✓
	✓		—	✓

*[Flash] for [White Bal] cannot be selected.

Viewing/deleting images

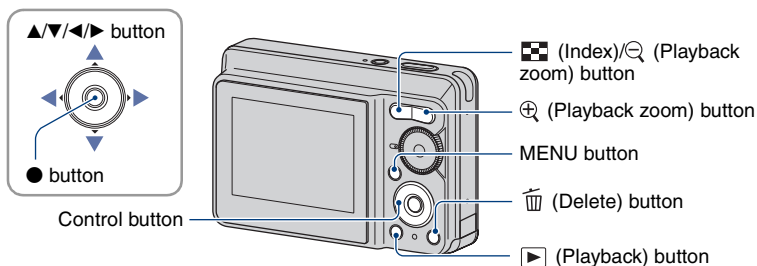

1 Press ▶ (Playback).

- If you press ▶ (Playback) when the camera is powered off, the camera is turned on automatically and set to playback mode. To switch to the shooting mode, press ▶ (Playback) again.

2 Select an image with ◀/▶ on the control button.

Movie:

Press ● to play back a movie. (Press ● again to stop playback.)

Press ▶ to fast forward, ◀ to rewind. (Press ● to return to normal playback.)

- You cannot listen to the audio with this camera when a movie is played back. To listen to the audio, connect with external outputs such as a TV, a speaker, etc.

🗑️ To delete images

- ① Display the image you want to delete and press 🗑️ (Delete).
- ② Select [Delete] with ▲, then press ●.

To cancel the deletion

Select [Exit], then press ●.

⊕🔍 To view an enlarged image (playback zoom)

Press ⊕ while displaying a still image.







To undo the zoom, press 🔍.

Adjust the portion with ▲/▼/◀/▶.

To cancel the playback zoom, press ●.

- To store enlarged images, see [Trimming] (page 47).











To view an index screen

Press  (Index) and select an image with ///. To display the next (previous) index screen, press /.

To return to the single image screen, press .







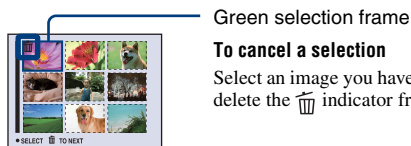



To delete images in index mode

- While an index screen is displayed, press  (Delete) and select [Select] with / on the control button, then press .
- Select the image you want to delete with ///, then press  to display the  (Delete) indicator on the selected image.



To cancel a selection

Select an image you have previously selected for deletion, then press  to delete the  indicator from the image.

- Press  (Delete).
 - Select [OK] with , then press .
- To delete all the images in the folder, select [All In This Folder] with / in step ① instead of [Select], then press .



Using menu items

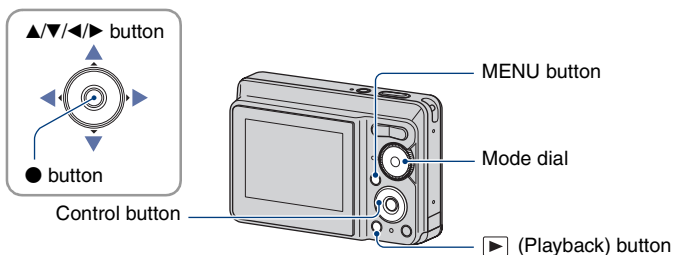

1 Recording: Turn on the camera, then set the mode dial.

Playback: Press ▶ (Playback).

- Different items are available depending on the position of the mode dial and Recording/Playback mode.

2 Press MENU to display the menu.

3 Select the desired menu item with ◀/▶ on the control button.

- If the desired item is invisible, keep pressing ◀/▶ until the item appears on the screen.
- Press ● after selecting an item in the Playback mode.

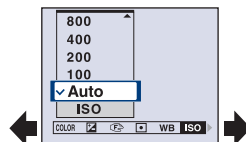

4 Select a setting with ▲/▼.

- The setting you select is zoomed and set.









5 Press MENU to turn off the menu.

- If there is an item that is not displayed, an ▲/▼ mark appears on the edges of the location where menu items usually appear. To display an item that is not displayed, select the mark with the control button.
- You cannot set items that are not available to select.







Shooting menu (page 32)

The available menu items vary depending on the mode setting (shooting/viewing), and the mode dial position in the shooting mode. Only the available items are displayed on the screen.

(✓ : available)

Mode dial position:		P	Scene	
COLOR (Color Mode)	—	✓	—	✓
 (EV)	✓	✓	✓	✓
 (Focus)	—	✓	—	—
 (Metering Mode)	—	✓	—	✓
WB (White Bal)	—	✓	✓ ^{*1}	✓
ISO	—	✓	—	—
Mode (REC Mode)	✓	✓	✓ ^{*1}	—
 (Flash Level)	—	✓	—	—
 (Sharpness)	—	✓	—	—
 (Setup)	✓	✓	✓	✓

Viewing menu (page 41)

- | | |
|--|---|
|  (Folder) |  (Protect) |
| DPOF |  (Print) |
|  (Slide) |  (Resize) |
|  (Rotate) |  (Setup) |
| Trimming ^{*2} | |

^{*1}) The operation is limited according to the Scene mode (page 27).

^{*2}) Available only for playback zoom

In this “Cyber-shot Handbook”, the available mode dial setting is shown as follows.

The selectable mode is displayed in white.

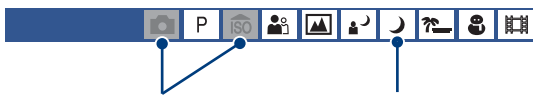







Unavailable Available

The default settings are marked with .

COLOR (Color Mode): Changing the vividness of the image or adding special effects



You can change the brightness of the image, accompanied by effects.

	B&W (B & W)	Sets the image to monochromatic color. 
	Sepia (SEPIA)	Sets the image to sepia color. 
	Natural (NATURAL)	Sets the image to quiet color. 
	Rich (RICH)	Sets the image to bright color. 
	Normal	Sets the image to standard color. 

• You can select only [Normal], [B&W] or [Sepia] when shooting movies.

 (EV): Adjusting the light intensity

Toward -

Toward +



Manually adjusts the exposure.



	+2.0EV	Toward +: Brightens an image.
	0EV	The exposure is determined automatically by the camera.
	-2.0EV	Toward -: Darkens an image.

- For details on the Exposure, see page 8.
- The compensation value can be set in 1/3EV increments.
- If you shoot a subject in extremely bright or dark conditions, or when you use the flash, the exposure adjustment may not be effective.

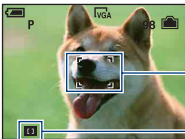
 (Focus): Changing the focus method

You can change the focus method. Use the menu when it is difficult to get the proper focus in auto focus mode.

<ul style="list-style-type: none"> ∞ (unlimited distance) 7.0 m 3.0 m 1.0 m 0.5 m 	<p>Focuses on the subject using a previously set distance to the subject (Focus preset).</p> <ul style="list-style-type: none"> Use “Focus preset” when it is difficult to get sharp focus with automatic focusing, such as when shooting a subject through a net or window.
<p>Center AF ()</p>	<p>Focuses on a subject in the center of the finder frame automatically.</p> <ul style="list-style-type: none"> Using the AF lock function together, you can compose the image the way you want. <div data-bbox="419 596 865 764" style="border: 1px solid black; padding: 5px;">  <p style="text-align: right; margin-right: 20px;">AF range finder frame</p> <p style="text-align: right; margin-right: 20px;">AF range finder frame indicator</p> </div>
<p>✓ Multi AF (Multipoint AF) ()</p>	<p>Focuses on a subject in all ranges of the finder frame automatically.</p> <ul style="list-style-type: none"> This mode is useful when the subject is not in the center of the frame. <div data-bbox="419 910 865 1077" style="border: 1px solid black; padding: 5px;">  <p style="text-align: right; margin-right: 20px;">AF range finder frame</p> <p style="text-align: right; margin-right: 20px;">AF range finder frame indicator</p> </div>

- AF stands for Auto Focus.
- Allow a margin of error in the distance setting of “Focus preset”. Pointing the lens up or down will increase error.
- When you use Digital Zoom, priority AF movement is given to subjects in or near the center of the frame. In this case the  or  indicator flashes and the AF range finder frame is not displayed.

 If the subject is out of focus

When shooting with the subject at the edge of the frame (or the screen) or when using [Center AF], the camera may not focus on a subject at the edge of the frame.



In such cases, do as follows:

- 1 Recompose the shot so that the subject is centered in the AF range finder, and press the shutter button halfway down to focus on the subject (AF lock).

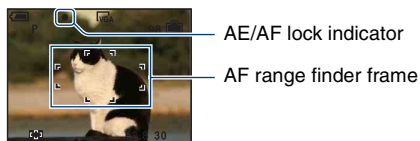



As long as you do not press the shutter button fully down, you can retry the procedure as many times as you want.

- 2 When the AE/AF lock indicator stops flashing and remains on, return to the fully composed shot, and press the shutter button fully down.

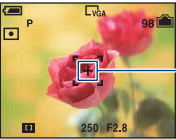

 (Metering Mode): Selecting the metering mode

Selects the metering mode that sets which part of the subject to measure to determine the exposure.





	Spot (Spot metering)  (Only for still image)	Measures only a part of the subject. <ul style="list-style-type: none"> This function is useful when the subject is backlit or when there is strong contrast between the subject and the background. 
	Center (Center-weighted metering) ()	Measures the center of the image, and determines the exposure based on the brightness of the subject there.
✓	Multi (Multi-pattern metering)	Divides into multiple regions and measures each region. The camera determines a well-balanced exposure.

- For details on the exposure, see page 8.
- When using spot metering or center-weighted metering, setting [Focus] to [Center AF] is recommended to focus on the metering position (page 34).

WB (White Bal): Adjusting the color tones





Adjusts color tones according to the surrounding light conditions. Use this function if image color appears unnatural.

Flash (WB)		<p>Adjusts for the flash conditions.</p> <ul style="list-style-type: none"> You cannot select this item when shooting movies. 
Incandescent (☀)		<p>Adjusts for places under an incandescent lamp, or under bright lighting, such as in a photo studio.</p> 
Fluorescent (☀)		<p>Adjusts for fluorescent lighting.</p> 
Cloudy (☁)		<p>Adjusts for a cloudy sky or shaded area.</p> 

Mode (REC Mode): Selecting the continuous shooting method



Selects whether the camera performs continuous shooting or not when you press the shutter button.

	Burst ()	<p>Records the maximum number of images in succession (refer to the following table) when you press and hold down the shutter button.</p> <ul style="list-style-type: none"> When “Recording” disappears, you can shoot the next image.  <ul style="list-style-type: none"> The flash is set to  (Flash forced off).
✓	Normal	Does not shoot continuously.

On the [Burst]

- When recording with the self timer, a series of a maximum of five images is recorded.
- The recording interval is approximately 1.2 seconds.
- When the battery level is low, or when the internal memory or “Memory Stick Duo” does not have sufficient space, you cannot shoot continuously.
- You may not be able to shoot images in the Burst mode depending on the Scene mode (page 27).

The maximum number of continuous shots

(units: images)

Size	Maximum continuous shots
7M	3
3:2	3
5M	4
3M	6
VGA	64
16:9	10

± (Flash Level): Adjusting the amount of flash light

Adjusts the amount of flash light.

	+ (±+)	Toward +: Makes the flash level higher.
✓	Normal	
	- (±-)	Toward -: Makes the flash level lower.

- To change flash mode, see page 22.
- If the subject is too bright or dark, this adjustment may have no effect.

□ (Sharpness): Adjusting the sharpness of the image

Toward -



Toward +

Adjusts the sharpness of the image.

	+ (□)	Toward +: Sharpens the image.
✓	Normal	
	- (□)	Toward -: Softens the image.

⊞ (Setup): Changing Setup items



See page 48.

The default settings are marked with .



(Folder): Selecting the folder for viewing images

Selects the folder containing the image you want to play back when using the camera with “Memory Stick Duo”.

<input type="checkbox"/>	OK	See the following procedure.
<input checked="" type="checkbox"/>	Cancel	Cancels the selection.

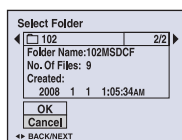
- ① Select the desired folder with /  on the control button.



- ② Select [OK] with , then press .

On the folders

The camera stores images in a specified folder of a “Memory Stick Duo”. You can change the folder or create a new one.

- To create a new folder → [Create REC. Folder] (page 52)
- To change the folder for recording images → [Change REC. Folder] (page 53)
- When multiple folders are created in the “Memory Stick Duo” and the first or last image in the folder is displayed, the following indicators appear.

: Moves to the previous folder.

: Moves to the next folder.



: Moves to either the previous or next folders.

 (Protect): Preventing accidental erasure

Protects images against accidental erasure. The  indicator appears on a protected image.

✓	Protect ()	See the following procedure.
	Exit	Exits the Protection function.

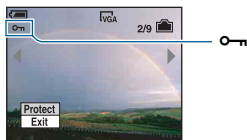

To protect images in single image mode

- ① Display the image you want to protect.
- ② Press MENU to display the menu.
- ③ Select [Protect] with /▶ on the control button, then press ●.
The image is protected and the  (protect) indicator appears on the image.



- ④ To protect other images, select the desired image with /▶, then press ●.

To protect images in index mode

- ① Press  (Index) to display the index screen.
- ② Press MENU to display the menu.
- ③ Select [Protect] with /▶ on the control button, then press ●.
- ④ Select [Select] with ▲/▼, then press ●.
- ⑤ Select the image you want to protect with ▲/▼/◀/▶, then press ●.
A green  indicator appears on the selected image.







- ⑥ Repeat step ⑤ to protect other images.
 - ⑦ Press MENU.
 - ⑧ Select [OK] with ▶, then press ●.
The  indicator turns white. The selected images are protected.
- To protect all images in the folder, select [All In This Folder] in step ④, and press ●. Select [On] with ▶, then press ●.

To cancel the protection



In single image mode

Press  in step ③ or ④ of “To protect images in single image mode.”

In index mode

- ① Select the image for which you want to remove protection in step ⑤ of “To protect images in index mode.”
- ② Press  to turn the  indicator gray.
- ③ Repeat the operation above for all images to be unprotected.
- ④ Press MENU, select [OK] with , and then press .

To cancel protection of all images in the folder

Select [All In This Folder] in step ④ of “To protect images in index mode,” and press . Select [Off] with , then press .

- Note that formatting the internal memory or “Memory Stick Duo” erases all the data stored on the recording media, even if the images are protected, and these images cannot be restored.
- It may take some time to protect an image.

DPOF: Adding a Print order mark

Adds a  (Print order) mark to images you want to print (page 80).

(Print): Printing images using a printer

Printing images shot with the camera.
See page 76.

 (Slide): Playing back a series of images





Plays back recorded images in order (Slide show).



Interval		
<input checked="" type="checkbox"/>	3 sec	Sets the slide show interval.
<input type="checkbox"/>	5 sec	
<input type="checkbox"/>	10 sec	
<input type="checkbox"/>	30 sec	
<input type="checkbox"/>	1 min	

Repeat		
<input checked="" type="checkbox"/>	On	Plays back images in a continuous loop.
<input type="checkbox"/>	Off	After all the images have been played back, the slide show ends.



Image		
You can select only when you use a "Memory Stick Duo" (not supplied).		
<input checked="" type="checkbox"/>	Folder	Plays back all the images in the selected folder.
<input type="checkbox"/>	All	Plays back all the images in a "Memory Stick Duo" in order.



<input type="checkbox"/>	Start	See the following procedure.
<input checked="" type="checkbox"/>	Cancel	Cancels the slide show.

① Select [Interval], [Repeat] and [Image] with /// on the control button.

② Select [Start] with /, then press .

The slide show starts.





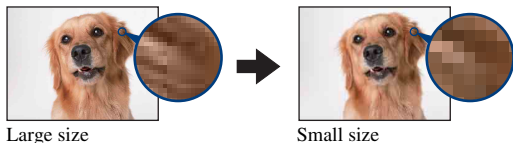

To end the slide show, press  to pause the slide show. Select [Exit] with , then press .

• When pausing during the slide show, you can display the previous/next image with /.

 (Resize): Changing the image size of a recorded image

You can change the image size of a recorded image (Resize), and save it as a new file. The original image is retained even after resizing.



<input type="checkbox"/>	7M	For details on guidelines for selecting the image size, see page 24.
<input type="checkbox"/>	5M	
<input type="checkbox"/>	3M	
<input type="checkbox"/>	VGA	
<input checked="" type="checkbox"/>	Cancel	Cancels resizing.





















- ① Display the image you want to resize.
 - ② Press MENU to display the menu.
 - ③ Select [Resize] with /  on the control button, then press .
 - ④ Select the desired size with / , then press .
- The resized image is recorded in the recording folder as the newest file.

- For details on Image Size, see page 10.
- You cannot change the size of movies.
- When you change from a small size to a large size, the image quality deteriorates.
- You cannot resize to an image size of 3:2 or 16:9.
- When you resize a 3:2 or 16:9 image, the upper and lower black portions will be displayed on the image.

 (Rotate): Rotating a still image

Rotates a still image.

	Rotates an image. See the following procedure.
OK	Determines the rotation. See the following procedure.
 Cancel	Cancels rotation.



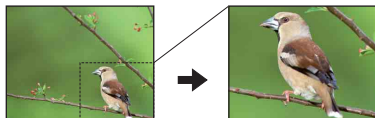

- ① Display the image to be rotated.
- ② Press MENU to display the menu.
- ③ Select [Rotate] with /  on the control button, then press .
- ④ Select [, , , , , , , , , , , , , , , , , ,

Trimming: Recording an enlarged image



Records an enlarged image (page 28) as a new file.

	Trimming	See the following procedure.
✓	Return	Cancels trimming.

- ① Press MENU during playback zoom to display the menu.
 - ② Select [Trimming] with  on the control button, then press .
 - ③ Select the image size with /, then press .

The image is recorded, and the original image is displayed again.
- The trimmed image is recorded as the newest file in the selected recording folder, and the original image is retained.
 - The quality of trimmed images may deteriorate.
 - You cannot trim to an image size of 3:2 or 16:9 aspect ratio.



Using Setup items

You can change the default settings using the Setup screen.

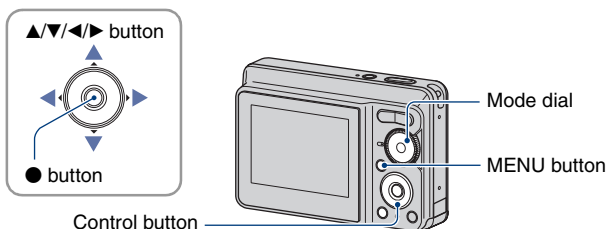

1 Press MENU to display the menu.

2 After pressing ▶ on the control button, go to the  (Setup) setting, then press ▶ again.

3 Press ▲/▼/◀/▶ on the control button to select the item you want to set.

- The frame of the selected item turns yellow.
-

4 Press ● to enter the setting.

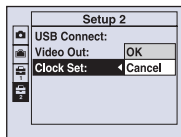

To turn off the  (Setup) screen, press MENU.

To return to the menu from the  (Setup) screen, press ◀ on the control button repeatedly.

- Press the shutter button halfway down to close the  (Setup) screen and return to the shooting mode.

When the menu is not displayed

Press MENU longer to display the  (Setup) screen.

To cancel the (Setup) setting

Select [Cancel] if it appears, then press ● on the control button. If it does not appear, select the previous setting again.

- This setting is maintained even when the power is turned off.

The default settings are marked with .

Digital Zoom

Selects the digital zoom mode. The camera enlarges the image using optical zoom (up to 3 \times). When the zoom scale exceeds 3 \times , the camera uses either smart or precision digital zoom.



 Smart (Smart zoom) 	Enlarges the image digitally with almost no distortion. This is not available when the image size is set to [7M] or [3:2].
Precision (Precision digital zoom) 	Enlarges all image sizes up to 6 \times total, but image quality deteriorates when zoom exceeds optical 3 \times .
Off	Does not use the digital zoom.

Image size and total zoom scale using Smart zoom (Including optical zoom 3 \times)



Size	Total zoom scale
5M	Approx. 3.6 \times
3M	Approx. 4.5 \times
VGA	Approx. 14 \times
16:9	Approx. 4.8 \times

- When you press the zoom button, the zoom scaling indicator appears as follows.

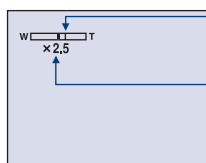

The W side of this line is the optical zoom area, and the T side is the digital zoom area

Zoom scaling indicator

- The total zoom scale of smart zoom/precision zoom includes the scale of the optical zoom.
- The AF range finder frame does not appear when using the digital zoom. The  or  indicator flashes, and AF operates with priority on subjects located near the center of the frame.
- When using the smart zoom, the image on the screen may look rough. However, this phenomenon has no effect on the recorded image.

Function Guide

When you operate the camera, the function guide appears.

✓	On	Displays the function guide.
	Off	Does not display the function guide.

Red Eye Reduction



The flash strobes two or more times before shooting to reduce the red-eye phenomenon when using the flash.

	On ()	Reduces the red-eye phenomenon.
✓	Off	Does not use Red Eye Reduction.

- To avoid blurring of images, hold the camera firmly until the shutter is released. It usually takes a second after you press the shutter button. Also be sure not to allow the subject to move during this period.
- Red-eye reduction may not produce the desired effects. It depends on individual differences and conditions, such as distance to the subject, or if the subject looked away from the pre-strobe.

Auto Review

Displays the recorded image on the screen for approximately two seconds immediately after shooting a still image.

✓	On	Uses the Auto Review.
	Off	Does not use Auto Review.

- If you press the shutter button halfway down, the recorded image display disappears and you can immediately shoot the next image.



This item does not appear when a “Memory Stick Duo” is inserted in the camera.

Format

Formats the internal memory.

- Note that formatting permanently erases all data in the internal memory, including even protected images.

- ① Select [OK] with ▲ on the control button, then press ●.
The message “All data in internal memory will be erased Ready?” appears.
- ② Select [OK] with ▲, then press ●.
The format is complete.

To cancel formatting

Select [Cancel] in step ① or ②, then press ●.

This item appears only when a “Memory Stick Duo” is inserted in the camera.

Format

Formats the “Memory Stick Duo”. A commercially available “Memory Stick Duo” is already formatted, and can be used immediately.

- Note that formatting permanently erases all data on a “Memory Stick Duo”, including even protected images.

- ① Select [OK] with ▲ on the control button, then press ●.
The message “All data in Memory Stick will be erased Ready?” appears.
- ② Select [OK] with ▲, then press ●.
The format is complete.

To cancel formatting

Select [Cancel] in step ① or ②, then press ●.

Create REC. Folder

Creates a folder in a “Memory Stick Duo” for recording images.

- ① Select [OK] with ▲ on the control button, then press ●.
The folder creation screen appears.

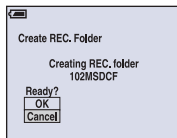

- ② Select [OK] with ▲, then press ●.
A new folder is created with a number incremented one higher than the largest number, and the folder becomes the current recording folder.

To cancel the folder creation

Select [Cancel] in step ① or ②, then press ●.

- When not creating a new folder, the “101MSDCF” folder is selected as the recording folder.
- You can create folders designated up to “999MSDCF.”
- Images are recorded in the newly created folder until you create another folder or select another recording folder.
- You cannot delete a folder with the camera. To delete a folder, use your computer, etc.
- Up to 4,000 images can be stored in one folder. When the folder capacity is exceeded, a new folder is automatically created.
- For details, see “Image file storage destinations and file names” (page 67).

Change REC. Folder

Changes the folder currently used for recording images.

- ① Select [OK] with ▲ on the control button, then press ●.
The folder selection screen appears.

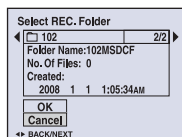

- ② Select the desired folder with ◀/▶, and [OK] with ▲, then press ●.

To cancel changing the recording folder

Select [Cancel] in step ① or ②, then press ●.

- You cannot select the "100MSDCF" folder as a recording folder.
- You cannot move recorded images to another folder.

Copy

Copies all images in the internal memory to a “Memory Stick Duo”.

- ① Insert a “Memory Stick Duo” having sufficient free capacity.
- ② Select [OK] with **▲** on the control button, then press **●**.
The message “All data in internal memory will be copied Ready?” appears.
- ③ Select [OK] with **▲**, then press **●**.
Copying starts.

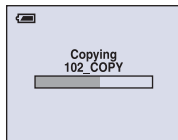

To cancel copying

Select [Cancel] in step ② or ③, then press **●**.

- Use batteries with enough power remaining. If you attempt to copy image files using batteries with little remaining charge, the batteries may run out, causing copying to fail or possibly corrupting the data.
- You cannot select images to copy.
- The original images in the internal memory are retained even after copying. To delete the contents of the internal memory, remove the “Memory Stick Duo” after copying, then format the internal memory ([Format] in [Internal Memory Tool]) (page 51).
- A new folder is created on the “Memory Stick Duo” and all the data will be copied to it. You cannot choose a specific folder and copy images to it.
- The  (Print order) marks on the images are not copied.

The default settings are marked with ✓.

Beep

Selects the sound produced when you operate the camera.

	Shutter	Turns on the shutter sound when you press the shutter button.
✓	On	Turns on the beep/shutter sound when you press the control button/press the shutter button.
	Off	Turns off the beep/shutter sound.

Language

Selects the language to be used in the menu items, warnings, and messages.

Initialize

Initializes the setting to the default setting.

Even if you execute this function, the images stored in the internal memory are retained.

- ① Select [OK] with ▲ on the control button, then press ●.
The message “Initialize all settings Ready?” appears.
- ② Select [OK] with ▲, then press ●.
The settings are reset to the default setting.

To cancel initializing

Select [Cancel] in step ① or ②, then press ●.

- Be sure not to power off the camera while initializing.

The default settings are marked with .

USB Connect

Selects the USB mode to be used when connecting the camera to a computer or a PictBridge compliant printer using the dedicated USB cable.

	PictBridge	Connects the camera to a PictBridge compliant printer (page 76).
	PTP	When [PTP] (Picture Transfer Protocol) is set and the camera is connected to a computer, the images in the recording folder on the camera are copied to the computer (Compatible with Windows XP and Mac OS X).
	Mass Storage	Establishes a Mass Storage connection between the camera and a computer or other USB device (page 65).

Video Out

Sets the video signal output according to the TV color system of the connected video equipment. The TV color systems differ depending on the country and region.

To view images on a TV screen, check the TV color system of the country or region of use (page 59).

NTSC	Sets the video output signal to NTSC mode (e.g., for the USA, Japan).
PAL	Sets the video output signal to PAL mode (e.g., for Europe).

Clock Set

Sets the date and time.

- ① Select [Clock Set] in the  (Setup2) screen.

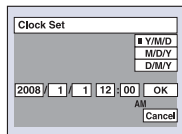

- ② Select [OK] with ▲ on the control button, then press ●.
- ③ Select the date display format with ▲/▼, then press ●.
- ④ Select each item with ◀/▶ and set the numeric value with ▲/▼, then press ●.
- ⑤ Select [OK] with ▶, then press ●.

To cancel the clock setting

Select [Cancel], then press ●.



Viewing images on a TV

You can view images on a TV by connecting the camera to a TV.
The connection varies according to the type of TV the camera is connected to.

Viewing images by connecting the camera to a TV with the supplied dedicated A/V cable.

Turn off both the camera and the TV before connecting the camera to the TV.

1 Connect the camera to the TV with the dedicated A/V cable (supplied).

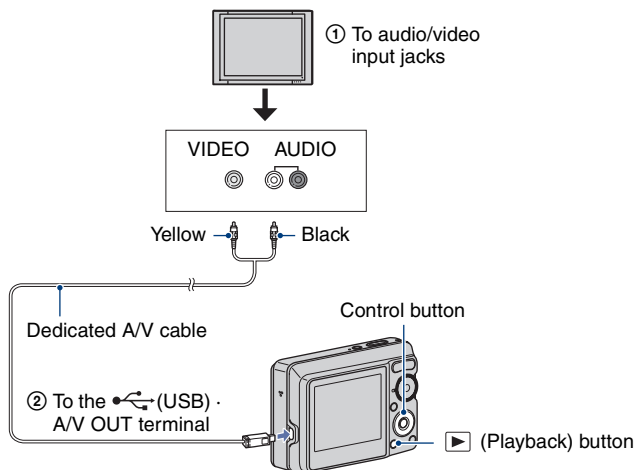

- If your TV has stereo input jacks, connect the audio plug (black) of the dedicated A/V cable to the left audio jack.

2 Turn on the TV and set the input.

- Refer also to the operating instructions supplied with the TV.

3 Press (Playback) to turn on the camera.

Images shot with the camera appear on the TV.

Press on the control button to select the desired image.

- When using your camera abroad, it may be necessary to switch the video signal output to match that of your TV system (page 56).

On TV color systems

If you want to view images on a TV screen, you need a TV with a video input jack and the dedicated A/V cable. The color system of the TV must match that of your digital still camera. Check the following lists for the TV color system of the country or region where the camera is used.

NTSC system

Bahama Islands, Bolivia, Canada, Central America, Chile, Colombia, Ecuador, Jamaica, Japan, Korea, Mexico, Peru, Surinam, Taiwan, the Philippines, the U.S.A., Venezuela, etc.

PAL system

Australia, Austria, Belgium, China, Czech Republic, Denmark, Finland, Germany, Holland, Hong Kong, Hungary, Italy, Kuwait, Malaysia, New Zealand, Norway, Poland, Portugal, Singapore, Slovak Republic, Spain, Sweden, Switzerland, Thailand, United Kingdom, etc.

PAL-M system

Brazil

PAL-N system

Argentina, Paraguay, Uruguay

SECAM system

Bulgaria, France, Guiana, Iran, Iraq, Monaco, Russia, Ukraine, etc.



Enjoying your Windows computer

For details on using a Macintosh computer, refer to “Using your Macintosh computer” (page 72). Illustrations of screens used in this section are based on the English version.

- Under Windows Vista, some names and operations may differ from those described below.



Install the software (supplied) first (page 62)



- Installing the software as follows:
 - “Picture Motion Browser”

Copying images to your computer (page 65)



- Copying images to your computer using “Picture Motion Browser”.
- Enjoying images using “Picture Motion Browser” as follows:
 - Viewing images saved on your computer
 - Editing images
 - Displaying the shooting locations of still images on maps online
 - Creating a disc with the images shot (requires CD or DVD disc writing drive)
 - Printing or saving still images with the date

Additional information on this product and answers to frequently asked questions can be found at the Sony Customer Support Website.
<http://www.sony.net/>

Recommended computer environment

The following environment is recommended for a computer connected to the camera.

Recommended environment for copying images

OS (pre-installed): Microsoft Windows 2000 Professional SP4, Windows XP* SP2/Windows Vista*

- Operation is not assured in an environment based on an upgrade of the operating systems described above or in a multi-boot environment.

USB jack: Provided as standard

Recommended environment for using “Picture Motion Browser”

OS (pre-installed): Microsoft Windows 2000 Professional SP4, Windows XP* SP2/Windows Vista*

CPU/Memory: Pentium III 500 MHz or faster, 256 MB of RAM or more (Recommended: Pentium III 800 MHz or faster and 512 MB of RAM or more)

Hard Disk: Disk space required for installation— approximately 200 MB

Display: Screen resolution: 1,024 × 768 dots or more

Colors: High Color (16-bit color) or more

* 64-bit editions and Starter (Edition) is not supported.

Notes on connecting the camera to a computer

- Operations are not guaranteed for all the recommended computer environments mentioned above.
- If you connect two or more USB devices to a single computer at the same time, some devices, including the camera, may not operate, depending on the types of USB devices you are using.
- Operations are not guaranteed when using a USB hub.
- Connecting the camera using a USB interface that is compatible with Hi-Speed USB (USB 2.0 compliant) allows advanced transfer (high speed transfer) as the camera is compatible with Hi-Speed USB (USB 2.0 compliant).
- There are two modes for a USB connection when connecting a computer, [Mass Storage] (default setting) and [PTP] modes. This section describes [Mass Storage] as an example. For details on [PTP], see page 56.
- When your computer resumes from a suspend or sleep mode, communication between the camera and your computer may not recover at the same time.

Installing the software (supplied)



You can install the software (supplied) using the following procedure.

- Log in as Administrator.

1 Turn on your computer, and insert the CD-ROM (supplied) into the CD-ROM drive.

The installation menu screen appears.



- If it does not appear, double-click  (My Computer) →  (SONYPICUTIL).
- Under Windows Vista, the AutoPlay screen may appear. Select “Run Install.exe.” and follow the instructions that appear on the screen to proceed with the installation.

2 Click [Install].

The “Choose Setup Language” screen appears.

3 Select the desired language, then click [Next].

The [Location Settings] screen appears.

4 Select the [Region] and [Country/Area], then click [Next].

When the [Welcome to the InstallShield Wizard for SonyPicture Utility] appears, click [Next].

The “License Agreement” screen appears. Read the agreement carefully. If you accept the terms of the agreement, click the radio button next to [I accept the terms of the license agreement] and then click [Next].

5 Follow the instructions on the screen to complete the installation.

- When the restarting confirmation message appears, restart the computer following the instructions on the screen.
- DirectX may be installed depending on the system environment of your computer.

6 Remove the CD-ROM after the installation is complete.

Installing the software (supplied)

After you install the software, the short cut icons for “Picture Motion Browser”, “Picture Motion Browser Guide”, are created on the desktop.



Picture Motion
Browser

- Double-click to start “Picture Motion Browser”.



Picture Motion
Browser Guide

- Double-click to start “Picture Motion Browser Guide”.

On the “Picture Motion Browser” (supplied)

You can use still images and movies from the camera more than ever by taking advantage of the software.

This section summarizes the “Picture Motion Browser”.

“Picture Motion Browser” overview

With the “Picture Motion Browser” you can:

- Import images shot with the camera and display them on the computer.
- Organize images on the computer on a calendar by shooting date to view them.
- Retouch (Red Eye Correction, etc.), print, and send still images as e-mail attachments, change the shooting date and more.
- Still images can be printed or saved with the date.
- You can create a data disc using a CD burner drive or DVD burner drive.
- For details, refer to “Picture Motion Browser Guide”.

To access “Picture Motion Browser Guide”

- Double-click “Picture Motion Browser Guide” icon on the desktop.
- From the Start menu, click [Start] → [All Programs] (in Windows 2000, [Programs]) → [Sony Picture Utility] → [Help] → [Picture Motion Browser Guide].

Starting and exiting the “Picture Motion Browser”

Starting the “Picture Motion Browser”

Double-click the  (Picture Motion Browser) icon on the desktop.

Or, from the Start menu: Click [Start] → [All Programs] (in Windows 2000, [Programs]) → [Sony Picture Utility] → [Picture Motion Browser].

- The confirmation message of the Information tool appears on the screen when starting the “Picture Motion Browser” for the first time. Select [Start]. This function informs you of news, such as software updates. You can change the setting later.

Exiting the “Picture Motion Browser”

Click  button in the top right corner of the screen.

Copying images to your computer using the “Picture Motion Browser”

Preparing the camera and the computer

1 Insert a “Memory Stick Duo” with recorded images into the camera.

- When copying images in the internal memory, this step is unnecessary.

2 Insert the batteries with enough power remaining in the camera, or connect the camera to a wall outlet (wall socket) with the AC Adaptor (not supplied).

- When you copy images to your computer using the batteries with little remaining charge, copying may fail or image data may become corrupted if the batteries shut down too soon.

3 Press (Playback), then turn on the computer.

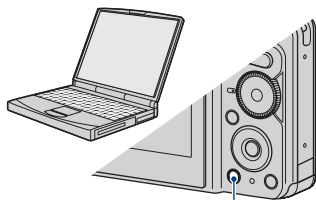

 (Playback) button

Connecting the camera to your computer

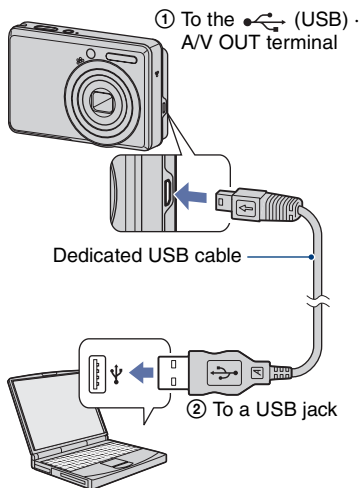

“USB Mode Mass Storage” appears on the screen of the camera.

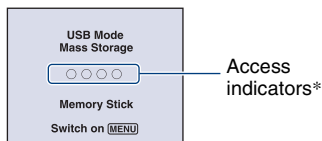

When a USB connection is established for the first time, your computer automatically runs a program to recognize the camera. Wait for a while.

* During communication, the access indicators turn red. Do not operate the computer until the indicators turn white.

- If “USB Mode Mass Storage” does not appear, set [USB Connect] to [Mass Storage] (page 56).

Copying images to a computer

1 Connects the camera to a computer as described “Connecting the camera to your computer”.

After making a USB connection, the [Import Media Files] screen of “Picture Motion Browser” appears automatically.



- If you use the Memory Stick slot, refer to page 69.
- In Windows XP/Windows Vista, if the AutoPlay Wizard appears, close it.

2 Import the images.

To start importing images, click the [Import] button.

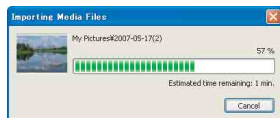

By default, images are imported into a folder created in “My Pictures” that is named with the date of importing.

- For details on the “Picture Motion Browser”, refer to “Picture Motion Browser Guide”.

Viewing images on your computer

When importing is complete, the “Picture Motion Browser” starts. Thumbnails of the imported images are displayed.

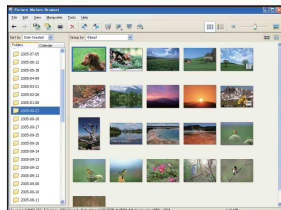

- The “My Pictures” folder is set as the default folder in “Viewed folders”.

Organize images on the computer on a calendar by shooting date to view them. For details, see the “Picture Motion Browser Guide”.

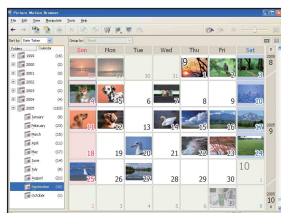

Example: Month display screen

To delete the USB connection

Perform the procedures from step ① to ④ below before:

- Disconnecting the dedicated USB cable.
- Removing a “Memory Stick Duo”.
- Inserting a “Memory Stick Duo” into the camera after copying images from the internal memory.
- Turning off the camera.

① Double-click  on the tasktray.



Double-click here

② Click  (USB Mass Storage Device) → [Stop].

③ Confirm the device on the confirmation window, then click [OK].

④ Click [OK].

The device is disconnected.

- Step ④ is unnecessary for Windows XP/Windows Vista.

Image file storage destinations and file names

The image files recorded with the camera are grouped as folders on the “Memory Stick Duo” or the internal memory.

Example: viewing folders on Windows XP

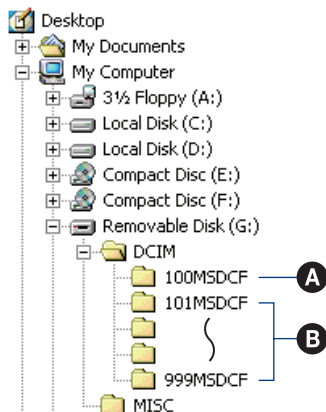

A Folder containing image data recorded using a camera not equipped with the folder creating function

B Folder containing image data recorded using the camera

When no new folders are created, there are folders as follows:

- “Memory Stick Duo”: “101MSDCF” only
- Internal memory: “101_SONY” only

- You cannot record any images to the “100MSDCF” folder. The images in this folder are available only for viewing.
- You cannot record/play back any images to the “MISC” folder.

- Image files are named as follows:
 - Still image files: DSC0□□□□.JPG
 - Movie files: MOV0□□□□.AVI
 - Index image files that are recorded when you record movies: MOV0□□□□.THM□□□□ stands for any number within the range from 0001 to 9999. The numerical portions of the name of a movie file recorded in movie mode and its corresponding index image file are the same.
- For more information about folders, see pages 41 and 52.

Copying images to a computer without “Picture Motion Browser”

You can copy images to your computer without “Picture Motion Browser” as follows.

For a computer with a Memory Stick slot

Remove the “Memory Stick Duo” from the camera and insert it in the Memory Stick Duo Adaptor. Insert the Memory Stick Duo Adaptor in the computer and copy the images.

- Even when you are using Windows 95/98/98 SecondEdition/NT/Me, you can copy images by inserting the “Memory Stick Duo” into the Memory Stick slot on your computer.
- If the “Memory Stick PRO Duo” is not recognized, see page 87.

For a computer without a Memory Stick slot

Make a USB connection and follow Stages to copy images.

- The screen displays shown in this section are the examples for copying images from “Memory Stick Duo”.
- The camera is not compatible with Windows 95/98/98 SecondEdition/NT/Me of the Windows operating system.
When you use a computer without a Memory Stick slot, use a commercially available Memory Stick Reader/Writer to copy images from a “Memory Stick Duo” to your computer.
- To copy images in the internal memory to your computer, copy the images to a “Memory Stick Duo” first, then copy them to your computer.

Copying images to a computer -Windows XP/Vista

This section describes an example of copying images to a “My Documents” (For Windows Vista: “Documents”).

1 Prepare the camera and a computer.

Perform the same procedure as described in “Preparing the camera and the computer” on page 65.

2 Connect the camera to your computer with the dedicated USB cable.

Perform the same procedure as described in “Connecting the camera to your computer” on page 65.

- If “Picture Motion Browser” is already installed, then [Import Media Files] automatically starts on “Picture Motion Browser”. Select [Cancel] to finish.

- 3** Click [Open folder to view files] → [OK](Only for Windows XP) as the wizard screen appears automatically on the desktop.

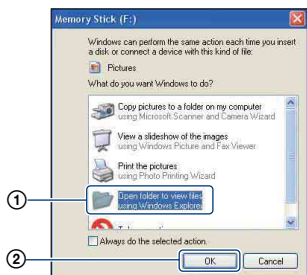

- When the wizard screen does not appear automatically, follow the procedure: → “For Windows 2000” on page 70.

- 4** Double-click [DCIM].

- 5** Double-click the folder where the image files you want to copy are stored. Then, right-click an image file to display the menu and click [Copy].

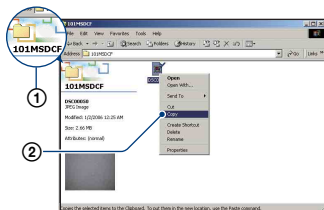

- On the storage destination of the image files, see page 67.

- 6** Double-click the [My Documents] (For Windows Vista: “Documents”) folder. Then, right-click on the “My Documents” window to display the menu and click [Paste].

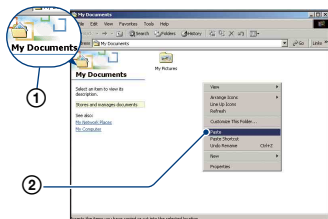

The image files are copied to the “My Documents” (For Windows Vista: “Documents”) folder.

- When an image with the same file name exists in the copy destination folder, the overwrite confirmation message appears. When you overwrite an existing image with a new one, the original file data is deleted. To copy an image file to the computer without overwriting, change the file name and then copy the image file. However, note that if you change the file name (page 71), you may not play back that image with the camera.

For Windows 2000

Double-click [My Computer] → [Removable Disk] after connecting the camera to your computer. Then, perform from step 4.

Viewing image files stored on a computer with the camera copying to the “Memory Stick Duo”

This section describes the process using a Windows computer as an example. When an image file copied to a computer no longer remains on a “Memory Stick Duo”, you can view that image again on the camera by copying the image file on the computer to a “Memory Stick Duo”.

- Skip step 1 if the file name set with the camera has not been changed.
- You may not be able to play back some images depending on the image size.
- Sony does not guarantee playback of image files on the camera if the files have been processed using a computer or recorded with another camera.
- When there are no folders in a “Memory Stick Duo”, create a folder (page 52) with the camera first, then copy the image files.

1 Right-click the image file, then click [Rename]. Change the file name to “DSC0□□□□”.

Enter a number from 0001 to 9999 for □□□□.

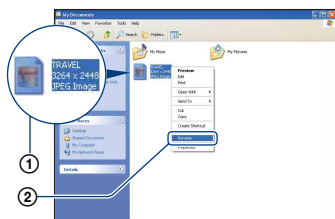

- If the overwrite confirmation message appears, enter a different number.
- An extension may be displayed depending on the computer settings. The extension for still images is JPG, and the extension for movies is AVI. Do not change the extension.

2 Copy the image file to the “Memory Stick Duo” folder in the following order.

- ① Right-click the image file, then click [Copy].
- ② Double-click [Removable Disk] or [Sony MemoryStick] in [My Computer].
- ③ Right-click the [□□□MSDCF] folder in the [DCIM] folder, then click [Paste].
 - □□□ stands for any number within the range from 100 to 999.

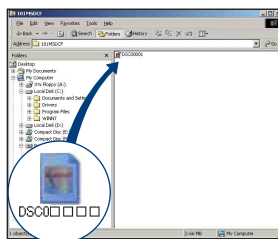

Using your Macintosh computer

You can copy images to your Macintosh computer.

- “Picture Motion Browser” is not compatible with Macintosh computers.

Recommended computer environment

The following environment is recommended for a computer connected to the camera.

Recommended environment for copying images

OS (pre-installed): Mac OS 9.1/9.2/ Mac OS X(v10.1 to v10.4)

USB jack: Provided as standard

Notes on connecting your camera to a computer

- Operations are not guaranteed for all the recommended computer environments mentioned above.
- If you connect two or more USB devices to a single computer at the same time, some devices, including your camera, may not operate depending on the types of USB devices you are using.
- Operations are not guaranteed when using a USB hub.
- Connecting the camera using a USB interface that is compatible with Hi-Speed USB (USB 2.0 compliant) allows advanced transfer (high speed transfer) as the camera is compatible with Hi-Speed USB (USB 2.0 compliant).
- There are two modes for a USB connection when connecting a computer, [Mass Storage] (default setting) and [PTP] modes. This section describes [Mass Storage] as an example. For details on [PTP], see page 56.
- When your computer resumes from the suspend or sleep mode, communication between your camera and your computer may not recover at the same time.

Copying and viewing images on a computer

1 Prepare the camera and a Macintosh computer.

Perform the same procedure as described in “Preparing the camera and the computer” on page 65.

2 Connect the dedicated USB cable.

Perform the same procedure as described in “Connecting the camera to your computer” on page 65.

3 Copy image files to the Macintosh computer.

- ① Double-click the newly recognized icon → [DCIM] → the folder where the images you want to copy are stored.
 - ② Drag and drop the image files to the hard disk icon.
The image files are copied to the hard disk.
- For details on the storage location of the images and file names, see page 67.

4 View images on the computer.

Double-click the hard disk icon → the desired image file in the folder containing the copied files to open that image file.

To delete the USB connection

Drag and drop the drive icon or the icon of the “Memory Stick Duo” to the “Trash” icon beforehand when you perform the procedures listed below, or the camera is disconnected from the computer.

- Disconnecting the dedicated USB cable
- Removing a “Memory Stick Duo”
- Inserting a “Memory Stick Duo” into the camera after copying images from the internal memory
- Turning off the camera

Technical Support

Additional information on this product and answers to frequently asked questions can be found at the Sony Customer Support Website.
<http://www.sony.net/>

Viewing “Cyber-shot Step-up Guide”

When you install “Cyber-shot Handbook”, “Cyber-shot Step-up Guide” is also installed. “Cyber-shot Step-up Guide” further introduces how to use the camera and optional accessories.

Viewing on Windows

Start from the shortcut icon on the desktop.

Viewing on Macintosh

- 1** Copy the [stepupguide] folder in the [stepupguide] folder to your computer.
 - 2** Select [stepupguide], [language] and then [GB] folder stored in the CD-ROM (supplied) and copy all the files in the [GB] folder, then write over them to the files in the [img] folder stored in [stepupguide] which is copied to your computer in the step 1.
 - 3** After copying is complete, double-click “stepupguide.hqx” in the [stepupguide] folder to uncompress it, then double-click the generated file “stepupguide”.
 - If an uncompress tool for HQX file is not installed, install the Stuffit Expander.
-



How to print still images

When you print images shot in [16:9] mode, both edges may be cut off, so be sure to check before printing (page 89).

Printing directly using a PictBridge compliant printer (page 76)



You can print images by connecting the camera directly to a PictBridge compliant printer.

Printing directly using a “Memory Stick” compliant printer

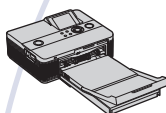

You can print images with a “Memory Stick” compliant printer. For details, see the operating instructions supplied with the printer.

Printing using a computer



You can copy images to a computer using the supplied “Picture Motion Browser” software and print the images. You can print images date inserted (page 64).

Printing at a shop (page 80)

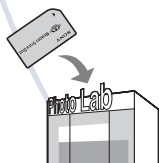

You can take a “Memory Stick Duo” containing images shot with your camera to a photo printing service shop. You can make a  (Print order) mark on the images which you want to print out in advance.

Printing images directly using a PictBridge compliant printer

Even if you do not have a computer, you can print images shot using your camera by connecting the camera directly to a PictBridge compliant printer.



- “PictBridge” is based on the CIPA standard. (CIPA: Camera & Imaging Products Association)

In single image mode

You can print a single image on a printing sheet.



In index mode

You can print several images at a reduced size on a printing sheet. You can print a set of either the same images (①) or different images (②).

①

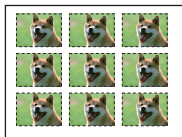

②



- An index print function may not be provided depending on the printer.
- The quantity of images that can be printed as an index image differ depending on the printer.
- You cannot print movies.
- If the  indicator flashes on the screen of the camera for about five seconds (error notification), check the connected printer.

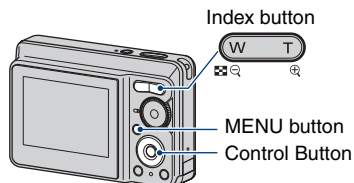

Stage 1: Preparing the camera

Prepare the camera to connect it to the printer with the dedicated USB cable.



- It is recommended to use batteries with enough power remaining or an AC Adaptor (not supplied) to prevent the power from turning off partway through printing.

1 Press MENU to display the menu.

2 Press  on the control button to select  (Setup).

3 Select  (Setup2) with , then select [USB Connect] with /.

4 Select [PictBridge] with /, then press .

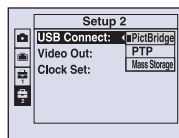

The USB mode is set.

Stage 2: Connecting the camera to the printer

1 Connect the camera to the printer.

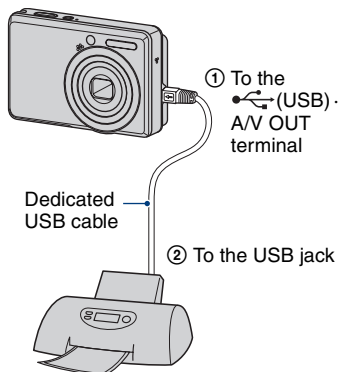

2 Turn on your camera and the printer.

After the connection is made, the  indicator appears.

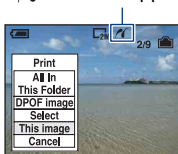

The camera is set to playback mode, then an image and the print menu appear on the screen.

Stage 3: Printing

Regardless of what the mode dial is set to, the print menu appears when you complete Stage 2.

1 Select the desired printing method with $\blacktriangle/\blacktriangledown$ on the control button, then press \bullet .

[All In This Folder]

Prints all the images in the folder.

[DPOF image]

Prints all the images with a  (Print order) mark (page 80) regardless of the displayed image.

[Select]

Selects images and prints all the selected images.

① Select the image you want to print with $\blacktriangle/\blacktriangledown$, then press \bullet .

The  mark appears on the selected image.

- To select other images, repeat this procedure.

② Select [Print] with \blacktriangledown , then press \bullet .

[This image]

Prints a displayed image.

- If you select [This image] and set [Index] to [On] in step 2, you can print a set of the same images as an index image.

2 Select print settings with ▲/▼/◀/▶.

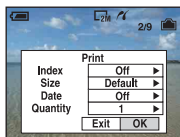

[Index]

Select [On] to print as an index image.

[Size]

Select the size of the printing sheet.

[Date]

Select [Day&Time] or [Date] to insert the date and time on images.

- When you choose [Date], the date will be inserted in the order you select (page 57). This function may not be provided depending on the printer.

[Quantity]

When [Index] is set to [Off]:

Select the number of sheets of an image that you want to print. The image will be printed as a single image.

When [Index] is set to [On]:

Select the number of sets of images that you want to print as an index image. If you selected [This image] in step 1, select the number of the same image you want to print side by side on a sheet as an index image.

- The designated number of images may not all fit onto a single sheet depending on the quantity of images.

3 Select [OK] with ▼/▶, then press ●.



The image is printed.

- Do not disconnect the dedicated USB cable while the  (PictBridge Connecting) indicator appears on the screen.

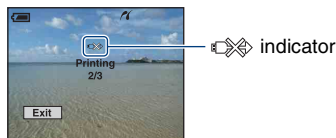



To print other images

After step 3, select [Select] and the desired image with ▲/▼, then perform from step 1.

To print images on the index screen

Perform “Stage 1: Preparing the camera” (page 76) and “Stage 2: Connecting the camera to the printer” (page 77), then proceed with the following.

When you connect the camera to a printer, the print menu appears. Select [Cancel] to turn off the print menu, then proceed as follows.

- ① Press  (Index).
The index screen appears.
- ② Press MENU to display the menu.
- ③ Select  (Print) with ▶, then press ●.
- ④ Select the desired printing method with ▲/▼, then press ●.

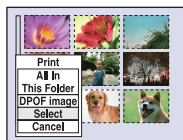

[Select]

Selects images and prints all the selected images.

Select the image you want to print with ▲/▼/◀/▶, then press ● to display the ✓ mark. (Repeat this procedure to select other images.) Then, press MENU.

[DPOF image]

Prints all the images with a  (Print order) mark regardless of the displayed image.

[All In This Folder]

Prints all the images in the folder.

- ⑤ Perform steps 2 and 3 of “Stage 3: Printing” (page 77).

Printing at a shop

You can take a “Memory Stick Duo” containing images shot with your camera to a photo printing service shop. As long as the shop supports photo printing services conforming to the DPOF, you can make a  (Print order) mark on images in advance so that you do not need to reselect them when you print them out at the shop.

- You cannot print images stored in the internal memory at a print shop directly from the camera. Copy the images to a “Memory Stick Duo”, then take the “Memory Stick Duo” to the print shop.

What is DPOF?

DPOF (Digital Print Order Format) is a function allowing you to make a  (Print order) mark on images of “Memory Stick Duo” that you want to print out later.

- You can also print the images with the  (Print order) mark using a printer that conforms to the DPOF (Digital Print Order Format) standard or using a PictBridge compliant printer.
- You cannot mark movies.



When taking a “Memory Stick Duo” to a shop

- Consult your photo printing service shop as to what types of “Memory Stick Duo” they can process.
- If a “Memory Stick Duo” cannot be processed by your photo printing service shop, copy the images you want to print out to another medium such as a CD-R and take it to the shop.
- Be sure to take the Memory Stick Duo Adaptor with it.
- Before you take image data to a shop, always copy (back up) your data to a disk.
- You cannot set the number of prints.
- When you want to superimpose dates on images, consult your photo printing service shop.

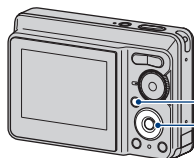
Marking in single image mode





MENU button
Control button

- 1** Display the image you want to print.
- 2** Press MENU to display the menu.
- 3** Select [DPOF] with , then press .

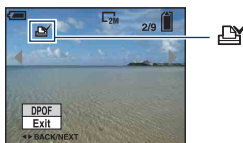
A  (Print order) mark is marked on the image.





- 4** To mark other images, display the desired image with , then press .

To remove the mark in single image mode

Press  in step 3 or 4.

Marking in index mode

- 1** Display the index screen (page 29).
- 2** Press MENU to display the menu.
- 3** Select [DPOF] with ◀/▶, then press ●.
- 4** Select [Select] with ▲/▼, then press ●.
 - You cannot add a  mark in [All In This Folder].
- 5** Select the image you want to mark with ▲/▼/◀/▶, then press ●.

A green  mark appears on the selected image.

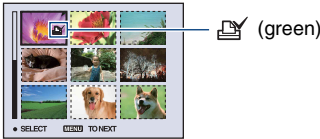
- 6** Repeat step 5 to mark other images.
- 7** Press MENU.
- 8** Select [OK] with ▶, then press ●.

The  mark turns white.

To cancel, select [Cancel] in step 4 or select [Exit] in step 8, then press ●.

To remove the mark in index mode

Select the images from which you want to remove the mark in step 5, then press ●.

To remove all the marks in the folder

Select [All In This Folder] in step 4, then press ●. Select [Off], then press ●.



If you experience trouble with your camera, try the following solutions.

1 Check the items on pages 83 to 91.

2 Remove the batteries, wait for about one minute, re-insert the batteries, then turn on the power.

3 Initialize the settings (page 55).

4 Consult your Sony dealer or local authorized Sony service facility.

Be aware that by sending the camera for repair, you give consent that the contents of the internal memory may be checked.

Click one of the following items to jump to the page explaining the symptom and cause or the appropriate corrective action.

Batteries and power 83

“Memory Stick Duo” 88

Shooting still images/movies 84

Internal memory 88

Viewing images 86

Printing 89

Deleting/Editing images 86

PictBridge compliant printer 89

Computers 87

Others 90

Batteries and power

The battery remaining indicator is incorrect, or sufficient battery remaining indicator is displayed but the power runs out too quickly.

- This phenomenon occurs when you use the camera in an extremely hot or cold location.
- When using alkaline batteries/Oxy Nickel Primary Battery (not supplied), the displayed time remaining may not be correctly indicated.
- The batteries are discharged. Insert new batteries or charged Nickel-Metal Hydride batteries (not supplied).
- When using the Nickel-Metal Hydride batteries, the poles of batteries or the terminals of the battery cover are dirty so the batteries are not charged sufficiently. Clean them with a cotton swab, etc. (page 97).
- When using the Nickel-Metal Hydride batteries, the displayed time remaining differs from the current one due to the memory effect (page 97), etc. Fully discharge and then charge the batteries to correct the display.
- The batteries are dead. Replace them with new ones.

The batteries run down too quickly.

- You are using the camera in an extremely cold location.
- The batteries are dead. Replace them with new ones.
- When using the Nickel-Metal Hydride batteries, charge them sufficiently.

Camera power is turned off automatically when you open the battery/"Memory Stick Duo" cover.

- This is not a malfunction. Turn off the camera before you open the battery/"Memory Stick Duo" cover.

Cannot turn on the camera.



- Insert the batteries correctly.
- Properly connect the AC Adaptor (not supplied).
- The batteries are discharged. Insert new batteries or charged Nickel-Metal Hydride batteries.
- The batteries are dead. Replace them with new ones.

The power turns off suddenly.

- If you do not operate the camera for about three minutes while the power is on, the camera turns off automatically to prevent wearing down the batteries. Turn on the camera again.
- The batteries are discharged. Insert new batteries or charged Nickel-Metal Hydride batteries.

Shooting still images/movies



Cannot record images.

- Check the free capacity of the internal memory or “Memory Stick Duo”. If it is full, do one of the following:
 - Delete unnecessary images (page 28).
 - Change the “Memory Stick Duo”.
- You cannot record images while charging the flash.
- When shooting a still image, set the mode dial to a position other than .
- Set the mode dial to  when shooting movies.

The subject is not visible on the screen.

- Your camera is set to the Playback mode. Press  (Playback) to change to the recording mode (page 28).







The image is out of focus.

- The subject is too close. Shoot in  (Macro) recording mode. Make sure to position the lens farther away from the subject than the shortest shooting distance, approximately 5 cm (2 inches) (W)/35 cm (13 7/8 inches) (T) from the front of the lens, when shooting (page 23).
-  (Twilight mode) or  (Landscape mode) is selected in the Scene mode when shooting still images.
- The Focus preset function is selected. Select the auto focus mode (page 34).
- Refer to “If the subject is out of focus” on page 35.

Zoom does not work.

- You cannot use the smart zoom when the image size is set to [7M] or [3:2].
- You cannot use the digital zoom while shooting movies.
- You cannot change the zoom scale while shooting movies.

The flash does not work.

- The flash is set to  (Flash forced off) (page 22).
- You cannot use the flash when:
 - [REC Mode] is set to [Burst] (page 39).
 -  (High Sensitivity mode) or  (Twilight mode) is selected in the Scene mode (page 27).
 - Shooting movies.
- Set the flash to  (Flash forced on) when  (Landscape mode),  (Beach mode), or  (Snow mode) is selected in the Scene mode (page 22).

Fuzzy specks appear in images shot using the flash.

- Particles (dust, pollen, etc.) in the air reflected the flash light and appeared in the image. This is not a malfunction (page 11).

The close-up shoot function (Macro) does not work.

-  (Twilight mode) or  (Landscape mode) is selected in the Scene mode (page 27).

The date and time are not displayed.

- While shooting, the date and time are not displayed. They are displayed only during playback.

Cannot insert dates on images.

- This camera does not have a feature for superimposing dates on images (page 89).
By using “Picture Motion Browser”, you can print or save images with the date (page 64).

The F value and shutter speed flash when you press and hold the shutter button halfway down.

- The exposure is incorrect. Correct the exposure (page 33).

The screen is too dark or too bright.

- Select the brightness of the LCD backlight (page 18).

The image is too dark.

- You are shooting a subject with a light source behind the subject. Select the metering mode (page 36) or adjust the exposure (page 33).

The image is too bright.

- Adjust the exposure (page 33).

The image colors are not correct.

- Set [Color Mode] to [Normal] (page 32).

Vertical streaks appear when you are shooting a very bright subject.

- The smear phenomenon is occurring and white, black, red, purple, or other streaks appear on the image. This phenomenon is not a malfunction.

Noise appears in the image when you view the screen in a dark place.

- The camera is attempting to increase the visibility of the screen by temporarily brightening the image under conditions of low illumination. There is no effect on the recorded image.

The eyes of the subject come out red.

- Set [Red Eye Reduction] in the  (Setup) menu to [On] (page 50).
- Shoot the subject at a distance closer than the flash range using the flash.
- Light the room and shoot the subject.

Dots appear and remain on the screen.

- This is not a malfunction. These dots are not recorded (page 2).
-

Cannot shoot images in succession.

- The internal memory or “Memory Stick Duo” is full. Delete unnecessary images (page 28).
 - The battery level is low. Insert new batteries or charged Nickel-Metal Hydride batteries (not supplied).
-

Viewing images

Cannot play back images.

- Press  (Playback) (page 28).
 - The folder/file name has been changed on your computer (page 71).
 - Sony does not guarantee playback of image files on the camera if the files have been processed using a computer or recorded with another camera.
 - The camera is in USB mode. Delete the USB connection (page 67).
-

The date and time are not displayed.

- The display indicators are turned off. Show the display indicators by pressing  (DISP) on the control button (page 18).
-

The image appears rough right after playback starts.

- This may happen due to image processing. This is not a malfunction.
-

The image does not appear on the TV.

- Check [Video Out] to see if the video output signal of your camera is set to the color system of your TV (page 56).
 - Check whether the connection is correct (page 58).
-

Deleting/Editing images

Cannot delete an image.

- Cancel the protection (page 43).
-

The resizing function does not work.

- You cannot resize movies.

Computers

Computer OS compatibility with camera is unknown.

- Check “Recommended computer environment” on page 61 for Windows, and page 72 for Macintosh.

“Memory Stick PRO Duo” is not recognized by a computer with a “Memory Stick” slot.

- Check that the computer and the Memory Stick Reader/Writer support “Memory Stick PRO Duo”. Users of computers and Memory Stick Readers/Writers made by manufacturers other than Sony should contact those manufacturers.
- If “Memory Stick PRO Duo” is not supported, connect the camera to the computer (pages 65 and 72). The computer recognizes the “Memory Stick PRO Duo”.

Your computer does not recognize your camera.

- Turn on the camera.
- When the battery level is low, insert new batteries or charged Nickel-Metal Hydride batteries (not supplied), or use the AC Adaptor (not supplied).
- Set [USB Connect] to [Mass Storage] in the  (Setup) menu (page 56).
- Use the dedicated USB cable (supplied) (page 65).
- Disconnect the dedicated USB cable from both the computer and the camera, and connect it again firmly.
- Disconnect all equipment other than the camera, the keyboard and the mouse from the USB connectors of your computer.
- Connect the camera directly to your computer without passing through a USB hub or other device (page 65).

Cannot copy images.

- Connect the camera and your computer correctly making a USB connection (page 65).
- Follow the designated copy procedure for your OS (pages 61 and 72).
- When you shoot images with a “Memory Stick Duo” formatted by a computer, you may not be able to copy the images to a computer. Shoot using a “Memory Stick Duo” formatted by your camera (page 52).

After making a USB connection, “Picture Motion Browser” does not start automatically.

- Make the USB connection after the computer is turned on (page 65).

Cannot play back images on your computer.

- If you are using “Picture Motion Browser”, refer to “Picture Motion Browser Guide” (page 64).
- Consult the computer or software manufacturer.

The image and sound are interrupted by noise when you view a movie on a computer.

- You are playing back the movie directly from the internal memory or the “Memory Stick Duo”. Copy the movie to the hard disk of your computer, then play back the movie from the hard disk (page 65).
-

Cannot print an image.

- Refer to the operation manual of the printer.
-

Images once copied to a computer cannot be viewed on the camera.

- Copy them to a folder recognized by the camera, such as “101MSDCF” (page 67).
 - Operate correctly (page 71).
-

“Memory Stick Duo”

Cannot insert a “Memory Stick Duo”.

- Insert it in the correct direction.
-

You have formatted a “Memory Stick Duo” by mistake.

- All the data on the “Memory Stick Duo” is deleted by formatting. You cannot restore it.
-

Internal memory

Cannot play back or record images using the internal memory.

- There is a “Memory Stick Duo” inserted in the camera. Remove it.
-

Cannot copy the data stored in the internal memory to a “Memory Stick Duo”.

- The “Memory Stick Duo” is full. Copy the image to the “Memory Stick Duo” with sufficient free capacity.
-

Cannot copy the data on the “Memory Stick Duo” or the computer to the internal memory.

- This feature is not available.
-

Printing

See “PictBridge compliant printer” together with the following items.

Images are printed with both edges cut off.

- Depending on your printer, all the edges of the image may be cut off. Especially when you print an image shot with the image size set to [16:9], the lateral end of the image may be cut off.
- When printing images using your printer, cancel the trimming or borderless settings. Consult the printer manufacturer as to whether the printer provides these functions or not.
- When having images printed at a digital print shop, ask the shop whether they can print the images without cutting off both edges.

Cannot print images with the date inserted.

- You can print images with the date inserted using “Picture Motion Browser” (page 64).
- This camera does not have a feature for superimposing dates on images. However, because the images shot with the camera include information on the recording date, you can print images with the date superimposed if the printer or the software can recognize Exif information. For compatibility with Exif information, consult the manufacturer of the printer or the software.
- If you use a photo printing service, ask them to superimpose the dates on images.

PictBridge compliant printer

A connection cannot be established.

- The camera cannot be connected directly to a printer that is not compliant with the PictBridge standard. Consult the printer manufacturer as to whether the printer is compliant with PictBridge or not.
- Check that the printer is turned on and can be connected to the camera.
- Set [USB Connect] to [PictBridge] in the  (Setup) menu (page 56).
- Disconnect and connect the dedicated USB cable again. If an error message is indicated on the printer, refer to the operating instructions supplied with the printer.

Cannot print images.

- Check that the camera and the printer are properly connected using the dedicated USB cable.
- Turn on the printer. For further information, refer to the operating instructions supplied with the printer.
- If you select [Exit] during printing, images may not be printed. Disconnect and connect the dedicated USB cable again. If you still cannot print your images, disconnect the dedicated USB cable, turn the printer off and then on, then connect the dedicated USB cable again.
- Movies cannot be printed.
- Images shot using cameras other than this camera or images modified with a computer may not be printed.

Printing is canceled.

- You disconnected the dedicated USB cable before the  (PictBridge Connecting) mark disappears.

Cannot insert the date or print images in the index mode.

- The printer does not provide these functions. Consult the printer manufacturer as to whether the printer provides these functions or not.
- The date may not be inserted in the index mode depending on the printer. Consult the printer manufacturer.

“---- -- --” is printed on the date-inserted part of the image.

- The image does not have the recording data so the date cannot be inserted. Set [Date] to [Off] and print the image again (page 78).

Cannot select the print size.

- Consult the printer manufacturer as to whether the printer can provide the desired size.

Cannot print the image at the size selected.

- When you use paper of a different size after connecting the printer to the camera, disconnect and then reconnect the dedicated USB cable.
- The print setting of the camera differs from that of the printer. Change the setting of either the camera (page 78) or the printer.

Cannot operate the camera after canceling printing.

- Wait for a while as the printer is carrying out the cancellation. It may take some time depending on the printer.

Others

Cannot reset the file-number.

- If you replace a recording medium, you cannot initialize file numbers with the camera. To initialize file numbers, format the “Memory Stick Duo” (page 51, 52) or the internal memory, and then initialize the settings (page 55). However, the data on the “Memory Stick Duo” or the internal memory will be deleted and all settings, including date, will be initialized.

The camera does not function with the lens portion extended.

- Do not attempt to force the lens that has stopped moving.
- Insert new batteries or charged Nickel-Metal Hydride batteries, then turn on the camera again.

The lens gets fogged.

- Moisture condensation has occurred. Turn off the camera and leave it for about an hour before using it.
-

The lens does not move when you turn off the camera.

- The batteries are discharged. Insert new batteries or charged Nickel-Metal Hydride batteries.
-

The camera becomes warm when you use it for a long time.

- This is not a malfunction.
-

The Clock Set screen appears when you turn on the camera.

- Set the date and time again (page 57).
-

You want to change the date or time.

- Set the date and time again (page 57).
-

Warning messages

Messages

If the following messages appear, follow the instructions.



- The battery level is low. Insert new ones or charged Nickel-Metal Hydride batteries (not supplied). Depending on the conditions of use or the type of battery, the indicator may flash even though there are still 5 to 10 minutes of remaining battery time left.

System error

- Turn the power off and then on again.

Internal memory error

- Turn the power off and then on again.

Reinsert the Memory Stick

- Insert the “Memory Stick Duo” correctly.
- The inserted “Memory Stick Duo” cannot be used in your camera (page 95).
- The “Memory Stick Duo” is damaged.
- The terminal section of the “Memory Stick Duo” is dirty.

Memory Stick type error

- The inserted “Memory Stick Duo” cannot be used in your camera (page 95).

Format error

- Format the media again (pages 51 and 52).

Memory Stick locked

- You are using the “Memory Stick Duo” with the write-protect switch, and the switch is set to the LOCK position. Set the switch to the recording position.

No memory space in internal memory

No memory space in Memory Stick

- Delete unnecessary images or files (page 28).

Read only memory

- Your camera cannot record or delete images on this “Memory Stick Duo”.

No file

- No images that can be played have been recorded in the internal memory.

No file in this folder

- No images that can be played have been recorded in this folder.
- You did not operate correctly when copying images from your computer (page 71).

Folder error

- A folder with the same first three digit number already exists on the “Memory Stick Duo” (for example: 123MSDCF and 123ABCDE). Select another folder, or create a new folder (pages 52, 53).

Cannot create more folders

- The folder with a name beginning with “999” exists on the “Memory Stick Duo”. You cannot create any folders if this is the case.

Cannot record

- The camera cannot record images in the selected folder. Select a different folder (page 53).

File error

- An error occurred while the image was playing back.

File protect

- Release the protection (page 42).

Image size over

- You are playing back an image of a size that cannot be played back on your camera.

Invalid operation

- You are trying to play back a file that is not compatible with the camera.

(Vibration warning indicator)

- Camera shake may occur due to insufficient light. Use the flash or mount the camera on a tripod to secure the camera.

Enable printer to connect

- [USB Connect] is set to [PictBridge], however the camera is connected to a non-PictBridge compliant device. Check the device.
- The connection is not established. Disconnect and connect the dedicated USB cable again. If an error message is indicated on the printer, refer to the operating instructions supplied with the printer.

Connect to PictBridge device

- You tried to print images before the printer connection was established. Connect to a PictBridge compliant printer.

No printable image

- You tried to execute [DPOF image] without placing a DPOF (Print order) mark on the image(s).
- You tried to execute [All In This Folder] while a folder that holds only movies was selected. You cannot print movies.

Printer busy

Paper error

No Paper

Ink error

Low Ink

No Ink

- Check the printer.

Printer error

- Check the printer.
- Check if the image you want to print is corrupted.



- The data transmission to the printer may not be completed yet. Do not disconnect the dedicated USB cable.

Processing

- The printer is canceling the current print job. You cannot print until it is finished. This may take time, depending on the printer.



You can use the camera, the AC-LS5K AC Adaptor (not supplied) in any country or region where the power supply is within 100 V to 240 V AC, 50/60 Hz.

- **Do not use an electronic transformer (travel converter), as this may cause a malfunction.**

On the “Memory Stick Duo”

A “Memory Stick Duo” is a compact, portable IC recording medium. The types of “Memory Stick Duo” that can be used with the camera are listed in the table below. However, proper operation cannot be guaranteed for all “Memory Stick Duo” functions.

“Memory Stick” type	Recording/ Playback
Memory Stick Duo (with MagicGate)	○*1
Memory Stick Duo (without MagicGate)	○*2
MagicGate Memory Stick Duo	○*1*2
Memory Stick PRO Duo	○*1
Memory Stick PRO-HG Duo	○*1*3

*1) “Memory Stick Duo”, “MagicGate Memory Stick Duo” and “Memory Stick PRO Duo” are equipped with MagicGate functions.

MagicGate is copyright protection technology that uses encryption technology. Data recording/playback that requires MagicGate functions cannot be performed with the camera.

*2) The camera is not compatible with high-speed data transfer using a parallel interface.

*3) The camera is not compatible with 8-bit parallel data transfer. Supports 4-bit parallel data transfer equivalent to “Memory Stick PRO Duo”.

- This product is compatible with “Memory Stick Micro” (“M2”). “M2” is an abbreviation for “Memory Stick Micro”.
- A “Memory Stick Duo” formatted with a computer is not guaranteed to operate with the camera.
- Data read/write speeds differ depending on the combination of the “Memory Stick Duo” and the equipment used.
- Do not remove the “Memory Stick Duo” while reading or writing data.
- Data may be corrupted in the following cases:
 - When the “Memory Stick Duo” is removed or the camera is turned off during a read or write operation.
 - When the “Memory Stick Duo” is used in locations subject to static electricity or electrical noise.
- We recommend backing up important data on a hard disk of your computer.
- Do not press down hard when you write down on the memo area.
- Do not attach a label on the “Memory Stick Duo” itself nor on a Memory Stick Duo Adaptor.
- When you carry or store the “Memory Stick Duo”, put it in the case supplied with it.
- Do not touch the terminal section of the “Memory Stick Duo” with your hand or a metal object.
- Do not strike, bend or drop the “Memory Stick Duo”.
- Do not disassemble or modify the “Memory Stick Duo”.
- Do not expose the “Memory Stick Duo” to water.
- Do not leave the “Memory Stick Duo” within the reach of small children. They might accidentally swallow it.
- Do not insert anything other than a “Memory Stick Duo” into the Memory Stick Duo slot. Otherwise, a malfunction may result.
- Do not use or store the “Memory Stick Duo” under the following conditions:
 - High temperature locations such as the hot interior of a car parked in direct sunlight
 - Locations exposed to direct sunlight
 - Humid locations or locations with corrosive substances present

Notes on using the Memory Stick Duo Adaptor (not supplied)

- To use a “Memory Stick Duo” with a “Memory Stick” compliant device, be sure to insert the “Memory Stick Duo” into a Memory Stick Duo Adaptor. If you insert a “Memory Stick Duo” into a “Memory Stick” compliant device without a Memory Stick Duo Adaptor, you might not be able to remove it from the device.
- When inserting a “Memory Stick Duo” into a Memory Stick Duo Adaptor, make sure the “Memory Stick Duo” is inserted facing in the correct direction, then insert it all the way in. Incorrect insertion may result in a malfunction.
- When using a “Memory Stick Duo” inserted into a Memory Stick Duo Adaptor with a “Memory Stick” compliant device, make sure that the Memory Stick Duo Adaptor is inserted facing the correct direction. Note that improper use may damage the equipment.
- Do not insert a Memory Stick Duo Adaptor into a “Memory Stick” compliant device without a “Memory Stick Duo” attached. Doing so may result in malfunction of the unit.

Notes on using “Memory Stick PRO Duo” (not supplied)

“Memory Stick PRO Duo” with a capacity up to 8 GB have been confirmed to operate properly with the camera.

Notes on using “Memory Stick Micro” (not supplied)

- To use a “Memory Stick Micro” with the camera, be sure to insert the “Memory Stick Micro” into a Duo-sized “M2” Adaptor. If you insert a “Memory Stick Micro” into the camera without a Duo-sized “M2” Adaptor, you might not be able to remove it from the camera.
- Do not leave the “Memory Stick Micro” within the reach of small children. They might accidentally swallow it.

On the batteries

Batteries you can and cannot use with your camera

Battery type	A	B	C
LR6 (size AA) alkaline batteries *	○	○	—
HR 15/51:HR6 (size AA) Nickel-Metal Hydride batteries *	—	○	○
ZR6 (size AA) Oxy Nickel Primary Battery *	—	○	—
Lithium batteries	—	—	—
Manganese batteries	—	—	—
Ni-Cd batteries	—	—	—

A: supplied

B: supported

C: rechargeable

* Before using batteries, read the following precaution for each type of battery.

As for unsupported batteries, operating performance cannot be ensured if voltage drops or other problems are caused by the nature of the battery.

On alkaline batteries (supplied)/Oxy Nickel Primary Battery (not supplied)

- Alkaline batteries/Oxy Nickel Primary Battery cannot be charged.
- Alkaline batteries/Oxy Nickel Primary Battery have a shorter life compared to the Nickel-Metal Hydride batteries. For this reason, the power may turn off even though the battery remaining indicator shows sufficient battery life remaining.
- Battery performance differs greatly depending on the manufacturer and the type of battery, and in some cases the battery life may be extremely short. This is especially true at low temperatures, and you may not be able to shoot at temperatures below 5°C (41°F).
- Do not mix new and old batteries.
- The battery remaining indicator may not display the correct information when using alkaline batteries/Oxy Nickel Primary Battery.

- Due to characteristics of alkaline batteries/Oxy Nickel Primary Battery, there is a large difference between the available shooting time and the available playback time. For this reason, the camera may turn off with the lens portion extended when you switch the mode dial. In this case, replace the batteries with new ones. Using the Nickel-Metal Hydride batteries allows you to shoot for longer periods of time.

On Nickel-Metal Hydride batteries (not supplied)

- Do not peel off the external seals or damage the batteries. Never use batteries from which the seals have been partially or completely removed, or batteries that have been split in any way. These may cause leakage, explosion, or heat-up of the battery, and personal scald or injury may be caused. These may cause a malfunction of the battery charger.
- Do not carry or store the Nickel-Metal Hydride batteries with metallic objects. Since metallic objects may short the + and - ends, resulting in the risk of heating or fire.
- If the poles of the Nickel-Metal Hydride batteries are dirty, the batteries may not charge properly. Wipe them with a dry cloth, etc.
- At the time of purchase, or when the Nickel-Metal Hydride batteries have not been used for a long time, they may not full charge. This is typical of this type of battery, and is not a malfunction. If this happens, repeatedly using up the batteries fully, and then recharging them should correct the problem.
- If you recharge Nickel-Metal Hydride batteries before fully using up the existing charge, the low battery warning may be displayed sooner than expected. This is called the "memory effect".* If this problem occurs, charging the batteries only after using up the existing charge will correct it.
 - * The "memory effect" - the situation in which the capacity of the battery is temporarily lowered.
- To use up the batteries completely, put the camera in the slide show mode (page 44) and leave it that way until the batteries are used up.
- Do not mix new and used batteries.
- Do not expose the battery to water. The battery is not water-resistant.

**A**

AC Adaptor.....	13
Adjusting EV.....	18, 33
AE/AF lock indicator.....	21, 35
AF lock.....	21, 35
AF range finder frame.....	35
Aperture.....	8
Auto adjustment mode.....	21
Auto Focus.....	6
Auto Review.....	50
AVI.....	68

B

B&W.....	32
Battery.....	97
Beach mode.....	26
Beep.....	55
Blur.....	7
Burst.....	39

C

Camera.....	49
Center AF.....	34
Center-weighted metering.....	36
Change REC. Folder.....	53
Clock Set.....	57
Cloudy.....	37
Color.....	9
Color Mode.....	32
Computer.....	60
Copying images.....	65, 72
Macintosh.....	72
Recommended environment.....	61, 72
Software.....	62
Viewing image files stored on a computer with the camera.....	71
Windows.....	60

Connecting

Computer.....	65
Printer.....	77
TV.....	58
Copy.....	54
Copying images to your computer.....	65
Create REC. Folder.....	52

D

Date.....	57
Daylight.....	38
Dedicated A/V cable.....	58
Dedicated USB cable.....	65, 77
Delete.....	28
Format.....	51, 52
Digital Zoom.....	49
DirectX.....	62
DISP.....	18
DPOF.....	80

E

EV.....	33
Exposure.....	8
Extension.....	71

F

File name.....	67
File storage destination.....	67
Flash (Shooting).....	11
Flash (White Bal).....	37
Flash forced off.....	22
Flash forced on.....	22
Flash Level.....	40
Flash mode.....	22
Fluorescent.....	37
Focus.....	6, 22, 34
Focus preset.....	34

Folder.....	41
Changing.....	53
Creating.....	52
Selecting.....	41
Format.....	51, 52
Function Guide.....	50

H

High Sensitivity mode.....	26
Histogram.....	18
Holding the camera.....	21

I

Identifying parts.....	12
Image file storage destinations and file names.....	67
Image quality.....	10
Image size.....	10, 24
Incandescent.....	37
Index mode printing.....	76
Index screen.....	29
Indicator.....	14
Initialize.....	55
Install.....	62
Internal memory.....	19
Internal Memory Tool.....	51
ISO.....	8, 38

J

JPG.....	68
----------	----

L

Landscape mode.....	26
Language.....	55
LCD Screen.....	18

M

Macintosh computer	72
Recommended environment	72
Macro	23
Mass Storage	56
“Memory Stick Duo”	95
Memory Stick Tool	52
Menu	30
Items	31
Shooting	32
Viewing	41
Metering Mode	36
Mode	39
Mode dial	20
Movie recording mode	20
Multi AF	34
Multi-pattern metering	36

N

Natural	32
NTSC	56

O

Optical zoom	22, 49
OS	61, 72
Overexposure	8

P

PAL	56
PC	60
PictBridge	56, 76
Picture Motion Browser	64
Pixel	10
Playback	28
Playback zoom	28
Precision digital zoom	49
Pressing halfway down	6

Print	75
Index mode	76
Single image mode	76
Print order mark	80
Printing at a shop	80
Printing directly	76
Program Auto mode	20
Protect	42
PTP	56

R

REC Mode	39
Red Eye Reduction	50
Resize	45
Rewind/Fast forward	28
Rich	32
Rotate	46

S

Scene Selection	25
Screen	
Changing the display	18
Indicator	14
LCD backlight	18
Select Folder	41
Self-timer	23
Sepia	32
Setup	40, 46, 48
Camera	49
Internal Memory Tool	51
Memory Stick Tool	52
Setup1	55
Setup2	56
Setup1	55
Setup2	56
Sharpness	40
Shooting	
Movie	21
Still image	21
Shooting menu	32

Shutter speed	8
Single image mode printing	76
Slide Show	44
Slow synchro	22
Smart zoom	49
Snow mode	26
Soft Snap mode	26
Software	62, 64
Spot metering	36
Spot metering cross hairs	36

T

Trimming	47
Troubleshooting	82
TV	58
Twilight mode	26
Twilight Portrait mode	26

U

Underexposure	8
USB Connect	56
USB-A/V OUT terminal	12
Using the camera abroad	94

V

VGA	24
Video Out	56
Viewing menu	41

W

Warning messages	92
White Bal	37
Windows computer	60
Recommended environment	61

Z

Zoom	22
------------	----

Additional information on this product and answers to frequently asked questions can be found at our Customer Support Website.

<http://www.sony.net/>